

CUTLESS[®] BEARINGS

Sleeve and Flanged Bearing Dimensional Catalog





CUTLESS® BEARINGS

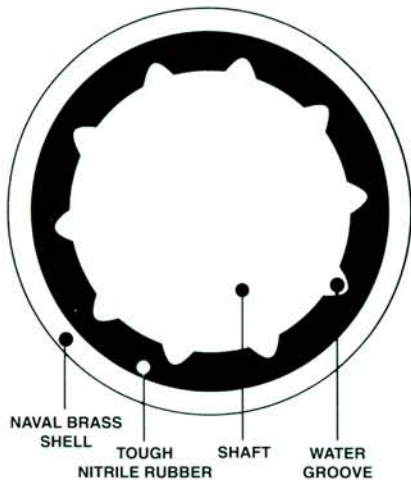

High Quality Materials & Design

Johnson Cutless® Sleeve and Flanged Bearings for heavy-duty commercial, government and pleasure craft applications, feature a specially formulated nitrile molded rubber lining firmly bonded to a shell material. Shells for sleeve bearings are seamless naval brass and are also available with a rugged non-metallic shell. Those for flanged bearings are one-piece centrifugally cast with integral flange. Other types of shells, such as stainless steel, monel, or aluminum can be furnished to order. All bearings are precision-machined to close tolerances and fully inspected.

The rubber, a proprietary formulation of extremely tough chemical and oil-resistant nitrile, is molded to fit the shaft in accordance with U.S. Navy BuShips approved clearances for efficient water lubrication. Radially-spaced grooves have edges rounded to promote the flow of water between the journal and the bearing rubber in a continuous lubricating film. Grit particles and other abrasives wipe into the grooves and are flushed away.

The controlled compliance of the rubber deflects under load and significantly reduces transfer of vibration of the vessel's hull. The result is smooth, low-friction operation — long service life — and greater overall operating efficiency.

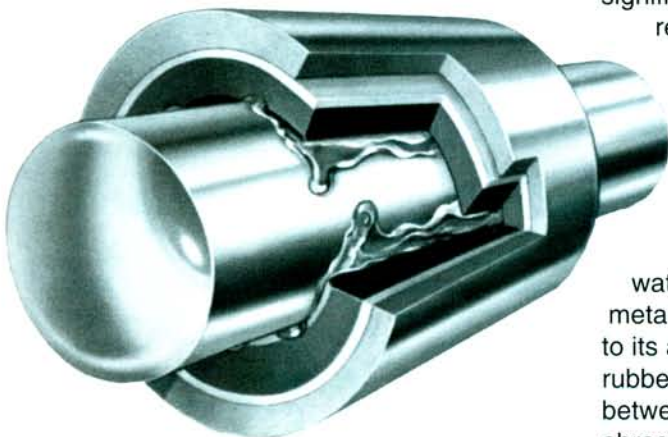

Water — The Ideal Lubricant

Water is the ideal lubricant because of its non-compressibility, cooling properties and abundant availability. When contained between sliding surfaces it forms a lubricating film with low coefficient of friction. And water is, of course, non-polluting. In rubber-lined bearings for metal shafts, water as a lubricant is at its most efficient — owing to its affinity for metal, but not for rubber. With Johnson Cutless® rubber bearings, the water enters the grooves and moves radially between the propeller shaft and the rubber. Contaminants and abrasives are flushed away through the grooves.



DURAMAX® MARINE

DURAMAX® MARINE

DURAMAX® MARINE

Better Concentricity

Some bearings are manufactured using centerless grinding techniques to finish the outside diameter. Centerless grinding the shell on a sleeve bearing provides a fine finish, but it may not be an indication of a high quality bearing. Since the centerless grinding process does not take the inside diameter of the bearing into account, the centers of the outside diameter and inside diameter may not be the same. When you install a bearing like this into a housing, the shaft may be off-center in the bearing. Johnson Cutless® Bearings are machined on the inside diameter. Once the inside diameter is bored to the correct dimension, a mandrel is inserted and the outside diameter is turned to the correct dimension. This results in good bearing concentricity and provides you with a quality product you can trust.

Quality Inspection

After machining the bearings, Duramax® Marine LLC inspects them to verify the accuracy of dimensions. Plug gages, one of the most accurate ways to measure a rubber bearing, are used on bearings for shaft sizes under 6-inches (152.40mm) in diameter. For larger sizes, Duramax® Marine LLC inspectors use ID micrometers. The bearings are also inspected for blemishes, imperfections and delamination in both the rubber and shell material. The bond between the rubber and shell material is also checked.

Class II Bearing on US Navy Qualified Products List

Duramax® Marine LLC has gone to great lengths to provide you with one of the best quality and highest-performing bearings available. Johnson Cutless® Bearing materials meet all requirements of MIL-B-17901B Class II. This United States military specification is more than just a classification approval; it is a stringent set of tests that a bearing must pass to become approved.

Research & Development Program

When a company is dedicated to producing the highest quality bearings, research and development becomes a critical aspect of creating technology for the industry. Duramax® Marine LLC has over 40 years of experience in the bearing business and operates a bearing test laboratory for the development of new bearing materials and performance testing of competitive materials. As a result, Duramax® Marine LLC is looked to as a leader in bearing technology and will continue to innovate and to provide you with longer lasting, better-performing bearings.

Excellent Distribution & Availability

In addition to high quality bearings, Duramax® Marine LLC is committed to having the bearings available for you when you need them. This is accomplished with field warehouses around the world. Duramax® Marine LLC has one of the largest distribution networks in the industry. The answer to your bearing needs is only a telephone call, fax or email away. If the bearing is not available locally, chances are it can be shipped from another location from stock.

Naval Brass Sleeve Bearings

INCH SIZE SERIES



Johnson Cutless® Naval Brass Sleeve Bearings adapt equally well to strut and stern tube mounts, and are often used effectively as rudder-stock and pintle bushings. Bearing diameters are precision fitted to the designated shaft size with the correct clearance for efficient water lubrication. External brass shells are machined and polished to provide easy fitting.

Specially formulated oil and chemical resistant nitrile rubber is securely bonded to the shell. Units with thin shells are available for the struts of small craft. Sleeve bearings are usually installed by light press-fitting and locked in place with cone-pointed set screws.

PRECAUTION: When shrink fitting of the bearing is required, chilling must be achieved by gradual cooling to not more than minus 20°F(-28°C) using freezer or regular ice (**DO NOT DRY ICE**). NOTE: Pounding or shocking the bearing while in the chilled state could cause the rubber to separate from the shell.

Approved Bearings: Johnson Cutless® Naval Brass Sleeve Bearings meet military specification MIL-B-17901 (Ships) Class II Full-Molded type and have full type approval from The American Bureau of Shipping.

Part Number	Code	Shaft Diameter Dimensions		Outside Diameter Dimensions		Length Dimensions		Metal Thickness Dimensions		Weight	
		inches	mm	inches	mm	inches	mm	inches	mm	lb.	kg.
870192100	ABLE	3/4	19.05	1 1/4	31.75	3	76.20	1/8	3.18	0.5	0.2
870222100	*ACID	7/8	22.23	1 1/4	31.75	3 1/2	88.90	1/16	1.59	0.4	0.2
870222101	APEX	7/8	22.23	1 3/8	34.93	3 1/2	88.90	1/8	3.18	0.7	0.3
870222102	ATOM	7/8	22.23	1 1/2	38.10	3 1/2	88.90	1/8	3.18	0.8	0.4
870252100	*BACK	1	25.40	1 1/4	31.75	4	101.60	3/64	1.19	0.4	0.2
870252144	*BADE	1	25.40	1 1/4	31.75	6	152.40	1/16	1.59	0.6	0.3
870252101	BAIT	1	25.40	1 3/8	34.93	4	101.60	1/16	1.59	0.5	0.2
870252102	BALE	1	25.40	1 1/2	38.10	4	101.60	1/8	3.18	0.7	0.3
870252103	BAND	1	25.40	1 5/8	41.28	4	101.60	1/8	3.18	0.9	0.4
870252104	BASE	1	25.40	2	50.80	4	101.60	1/8	3.18	1.3	0.6
870292100	*BEAM	1 1/8	28.58	1 1/2	38.10	4 1/2	114.30	1/16	1.59	0.6	0.3
870292101	BELT	1 1/8	28.58	1 5/8	41.28	4 1/2	114.30	1/8	3.18	1.0	0.5
870292102	BEND	1 1/8	28.58	1 3/4	44.45	4 1/2	114.30	1/8	3.18	1.1	0.5
870292103	BILL	1 1/8	28.58	2	50.80	4 1/2	114.30	1/8	3.18	1.4	0.6
870322100	*BIND	1 1/4	31.75	1 1/2	38.10	5	127.00	1/16	1.59	0.6	0.3
870322101	BIRD	1 1/4	31.75	1 3/4	44.45	5	127.00	1/8	3.18	1.2	0.5
870322102	BITE	1 1/4	31.75	2	50.80	5	127.00	1/8	3.18	1.5	0.7
870322103	BLOW	1 1/4	31.75	2 1/8	53.98	5	127.00	1/8	3.18	1.7	0.8
870352100	BOAT	1 3/8	34.93	1 7/8	47.63	5 1/2	139.70	1/8	3.18	1.4	0.6
870352101	BOLD	1 3/8	34.93	2	50.80	5 1/2	139.70	1/8	3.18	1.5	0.7
870352102	BOND	1 3/8	34.93	2 1/8	53.98	5 1/2	139.70	1/8	3.18	1.8	0.8
870352103	BOOT	1 3/8	34.93	2 3/8	60.33	5 1/2	139.70	1/8	3.18	1.8	0.8
870382100	BOSS	1 1/2	38.10	2	50.80	6	152.40	1/8	3.18	1.6	0.7
870382101	BRAD	1 1/2	38.10	2 3/8	60.33	6	152.40	1/8	3.18	2.2	1.0
870412100	BREW	1 5/8	41.28	2 1/8	53.98	6 1/2	165.10	1/8	3.18	2.0	1.9
870412101	BRIM	1 5/8	41.28	2 5/8	66.68	6 1/2	165.10	1/8	3.18	2.6	1.2
870452100	BROW	1 3/4	44.45	2 3/8	60.33	7	177.80	1/8	3.18	2.3	1.0
870452101	BUCK	1 3/4	44.45	2 5/8	66.68	7	177.80	1/8	3.18	2.8	1.3
870482100	BULB	1 7/8	47.63	2 5/8	66.68	7 1/2	190.50	1/8	3.18	2.8	1.3
870482101	BULL	1 7/8	47.63	2 15/16	74.61	7 1/2	190.50	3/32	2.38	3.1	1.4
870512100	CALL	2	50.80	2 5/8	66.68	8	203.20	1/8	3.18	2.8	1.3
870512143	CAMP	2	50.80	2 3/4	69.85	8	203.20	1/8	3.18	3.3	1.5
870512101	CALM	2	50.80	3	76.20	8	203.20	1/8	3.18	3.8	1.7
870542100	CAME	2 1/8	53.98	2 15/16	74.61	8 1/2	215.90	1/8	3.18	3.1	1.4
870542101	CAPE	2 1/8	53.98	3 1/8	79.38	8 1/2	215.90	1/8	3.18	4.1	1.9
870572100	CARE	2 1/4	57.15	2 15/16	74.61	9	228.60	3/32	2.38	3.1	1.4
870572133	CARD	2 1/4	57.15	3	76.20	9	228.60	1/8	3.18	3.9	1.8
870572101	CART	2 1/4	57.15	3 1/8	79.38	9	228.60	1/8	3.18	4.3	2.0
870572102	CASE	2 1/4	57.15	3 3/8	85.73	9	228.60	1/8	3.18	5.1	2.3

All Bearings Shown Are Carried in Stock

*Slimline Bearing

NAVAL BRASS SLEEVE BEARINGS - INCH

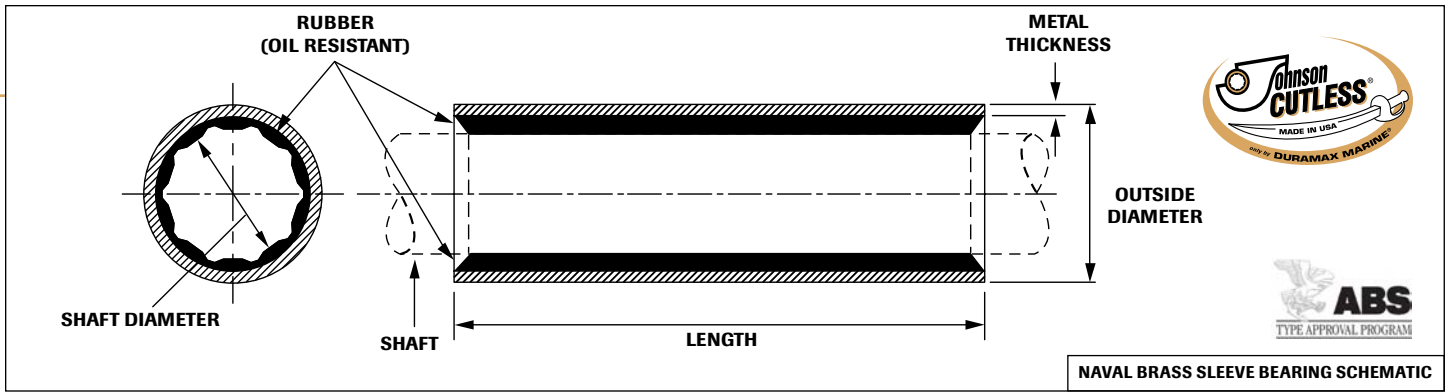

Part Number	Code	Shaft Diameter Dimensions		Outside Diameter Dimensions		Length Dimensions		Metal Thickness Dimensions		Weight	
		inches	mm	inches	mm	inches	mm	inches	mm	lb.	kg.
870602100	COOK	2 3/8	60.33	3 3/8	85.73	9 1/2	241.30	1/8	3.18	4.8	2.2
870642100	CORD	2 1/2	63.50	3 1/8	79.38	10	254.00	1/8	3.18	4.5	2.0
870642101	CORN	2 1/2	63.50	3 3/8	85.73	10	254.00	1/8	3.18	5.1	2.3
870642134	COVE	2 1/2	63.50	3 1/2	88.90	10	254.00	5/32	3.97	6.6	3.0
870672100	CRAB	2 5/8	66.68	3 3/8	85.73	10 1/2	266.70	1/8	3.18	5.2	2.4
870702100	CROW	2 3/4	69.85	3 3/8	85.73	11	279.40	1/8	3.18	4.8	2.2
870702139	CUBE	2 3/4	69.85	3 1/2	88.90	11	279.40	5/32	3.97	6.6	3.0
870702101	CURD	2 3/4	69.85	3 3/4	95.25	11	279.40	1/8	3.18	6.6	3.0
870732100	CURE	2 7/8	73.03	3 3/4	95.25	11 1/2	292.10	1/8	3.18	6.5	2.9
870762100	DANE	3	76.20	3 3/4	95.25	12	304.80	1/8	3.18	6.8	3.1
870762101	DARE	3	76.20	4	101.60	12	304.80	1/8	3.18	7.7	3.5
870802100	DARK	3 1/8	79.38	4 1/4	107.95	12 1/2	317.50	1/8	3.18	8.6	3.9
870832100	DARN	3 1/4	82.55	4	101.60	13	330.20	1/8	3.18	7.8	3.5
870832101	DELL	3 1/4	82.55	4 1/4	107.95	13	330.20	1/8	3.18	8.7	3.9
870862100	DIKE	3 3/8	85.73	4 1/2	114.30	13 1/2	342.90	1/8	3.18	10.2	4.6
870892100	DINE	3 1/2	88.90	4 1/4	107.95	14	355.60	1/8	3.18	8.9	4.0
870892101	DOCK	3 1/2	88.90	4 1/2	114.30	14	355.60	1/8	3.18	10.3	4.7
870922100	DOLE	3 5/8	92.08	4 1/2	114.30	14 1/2	368.30	1/8	3.18	10.0	4.5
870952100	DONE	3 3/4	95.25	4 1/2	114.30	15	381.00	1/8	3.18	9.6	4.4
870952101	DOVE	3 3/4	95.25	5	127.00	15	381.00	3/16	4.76	16.5	7.5
870952102	DRAW	3 3/4	95.25	5 1/4	133.35	15	381.00	3/16	4.76	18.2	8.3
870992100	DULL	3 7/8	98.43	5 1/4	133.35	15 1/2	393.70	3/16	4.76	18.7	8.5
871022100	EARN	4	101.60	5	127.00	16	406.40	3/16	4.76	16.9	7.7
871022101	EASE	4	101.60	5 1/4	133.35	16	406.40	3/16	4.76	18.7	8.5
871052100	ECHO	4 1/8	104.78	5 1/4	133.35	16 1/2	419.10	3/16	4.76	19.0	8.6
871082100	EDIT	4 1/4	107.95	5 1/2	139.70	17	431.80	3/16	4.76	22.0	10.0
871112100	ELSE	4 3/8	111.13	5 3/4	146.05	17 1/2	444.50	3/16	4.76	23.7	10.8
871152100	EPIC	4 1/2	114.30	5 1/2	139.70	18	457.20	3/16	4.76	21.3	9.7
871152101	EDGE	4 1/2	114.30	5 3/4	146.05	18	457.20	3/16	4.76	23.7	10.8
871182100	EVEN	4 5/8	117.48	6 1/8	155.58	18 1/2	469.90	1/4	6.35	42.0	19.1
871212100	EVER	4 3/4	120.65	6 1/8	155.58	19	482.60	1/4	6.35	41.0	18.6
871242100	EVIL	4 7/8	123.83	6 1/8	155.58	19 1/2	495.30	1/4	6.35	41.7	18.9
871272100	FACE	5	127.00	6 1/8	155.58	20	508.00	1/4	6.35	42.3	19.2
871272101	FACT	5	127.00	6 1/2	165.10	20	508.00	1/4	6.35	48.7	22.1
871342100	FADE	5 1/4	133.35	6 3/4	171.45	21	533.40	1/4	6.35	50.3	22.8
871342101	FARE	5 1/4	133.35	7	177.80	21	533.40	1/4	6.35	55.0	24.9
871372100	FEAR	5 3/8	136.53	6 3/4	171.45	21 1/2	546.10	1/4	6.35	51.3	23.3
871372101	FELT	5 3/8	136.53	7	177.80	21 1/2	546.10	1/4	6.35	56.0	25.4
871402100	FIND	5 1/2	139.70	7	177.80	22	558.80	1/4	6.35	56.0	25.4
871432100	FLAT	5 5/8	142.88	7	177.80	22 1/2	571.50	1/4	6.35	55.5	25.2
871462100	FORK	5 3/4	146.05	7	177.80	23	584.20	1/4	6.35	56.5	25.6
871502100	FUEL	5 7/8	149.23	7 1/2	190.50	24	609.60	1/4	6.35	65.8	29.8
871532100	GALE	6	152.40	7 1/2	190.50	24	609.60	1/4	6.35	66.0	29.9
871662100	GOLD	6 1/2	165.10	8 3/8	212.73	30	762.00	7/16	11.11	150.0	68.0

All Bearings Shown Are Carried in Stock

Naval Brass Sleeve Bearings

METRIC SIZE SERIES



Johnson Cutless® Naval Brass Sleeve Bearings adapt equally well to strut and stern-tube mounts, and are often used effectively as rudder-stock and pintle bushings. Bearing diameters are precision fitted to the designated shaft size with the correct clearance for efficient water lubrication. External brass shells are machined and polished to provide easy fitting. Specially formulated oil and chemical resistant nitrile rubber is securely bonded to the shell. Units with thin shells are available for the struts of small craft. Sleeve Bearings are usually installed by light press-fitting and locked in place with cone-pointed set screws.

PRECAUTION: When shrink fitting of the bearing is required, chilling must be achieved by gradual cooling to not more than minus 20°F(-28°C) using freezer or regular ice (**DO NOT DRY ICE**). NOTE: Pounding or shocking the bearing while in the chilled state could cause the rubber to separate from the shell.

Approved Bearings: Johnson Cutless® Naval Brass Sleeve Bearings meet military specification MIL-B-17901 (Ships) Class II Full-Molded type and have full type approval from The American Bureau of Shipping.

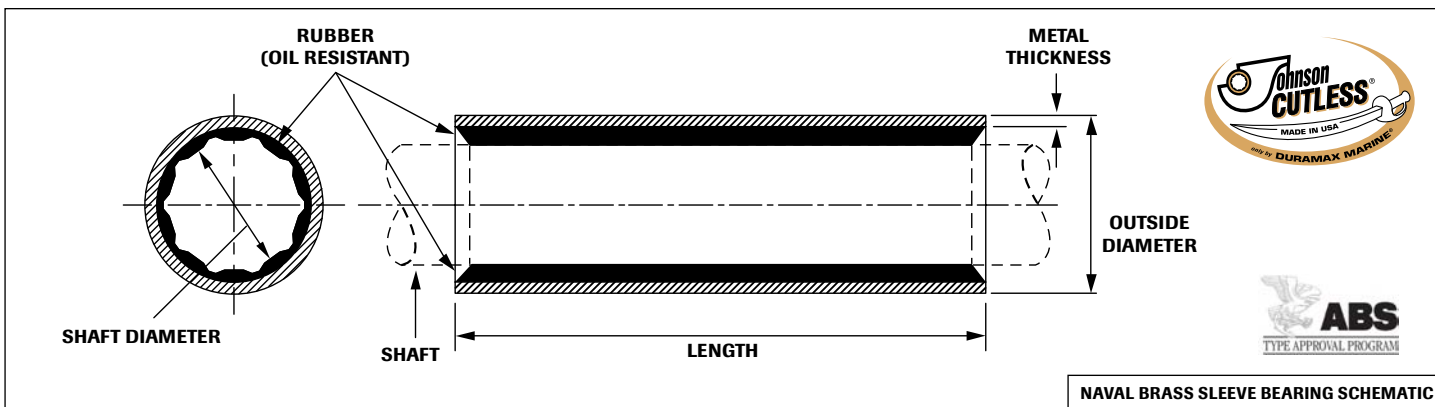

Part Number	Shaft Diameter (mm)	Outside Diameter (mm)	Length (mm)	Metal Thickness (mm)	Weight	
					lb.	kg.
870254100	25	40	100	2.54	0.80	0.4
870284100	28	42	112	2.35	0.70	0.3
870304100	30	45	120	3.07	1.20	0.5
870324100	32	45	128	3.07	1.30	0.6
870354100	35	50	140	3.07	1.50	0.7
870384100	38	55	152	3.07	1.70	0.8
870404100	40	55	160	3.07	1.80	0.8
870454100	45	65	180	3.30	2.80	1.3
870504100	50	70	200	3.26	3.10	1.4
870554100	55	75	220	2.58	3.80	1.7
870604100	60	80	240	3.26	4.50	2.0
870654100	65	85	260	2.82	4.80	2.2
870704100	70	90	280	4.76	5.80	2.6
870754100	75	95	300	3.05	6.70	3.0
870804100	80	100	320	3.17	7.70	3.5
870854100	85	105	340	3.19	8.70	3.9
870904100	90	110	360	4.78	12.50	5.7
870954100	95	115	380	4.51	13.30	6.0
871004100	100	125	400	3.77	14.30	6.5
871054100	105	130	420	4.52	17.60	8.0
871104100	110	135	440	4.51	19.00	8.6
871154100	115	145	460	4.25	25.30	11.0
871204100	120	155	480	6.06	31.60	14.0
871304100	130	170	520	5.63	49.00	22.0
871404100	140	180	560	7.45	56.00	25.0

Non-Metallic Sleeve Bearings

METRIC SIZE SERIES



Johnson Cutless® Non-Metallic Sleeve Bearings feature a dense structure of engineered reinforced thermoset plastic. The specially compounded Nitrile Rubber is securely bonded to the shell with all tolerances maintained for proper lubrication. Being non-corrosive and inherently resistant to all known chemicals, oil and grease, as well as being anti-electrolytic, the Johnson Cutless® Non-Metallic Sleeve Bearings are ideally suited for installations wherever corrosion or electrolysis is a problem.

PRECAUTION: When shrink fitting of the bearing is required, chilling must be achieved by gradual cooling to not more than minus 20°F(-28°C) using freezer or regular ice (**DO NOT DRY ICE**). NOTE: Pounding or shocking the bearing while in the chilled state could cause the rubber to separate from the shell.

Approved Bearings: Johnson Cutless Non-Metallic Sleeve Bearings have full type approval from The American Bureau of Shipping.

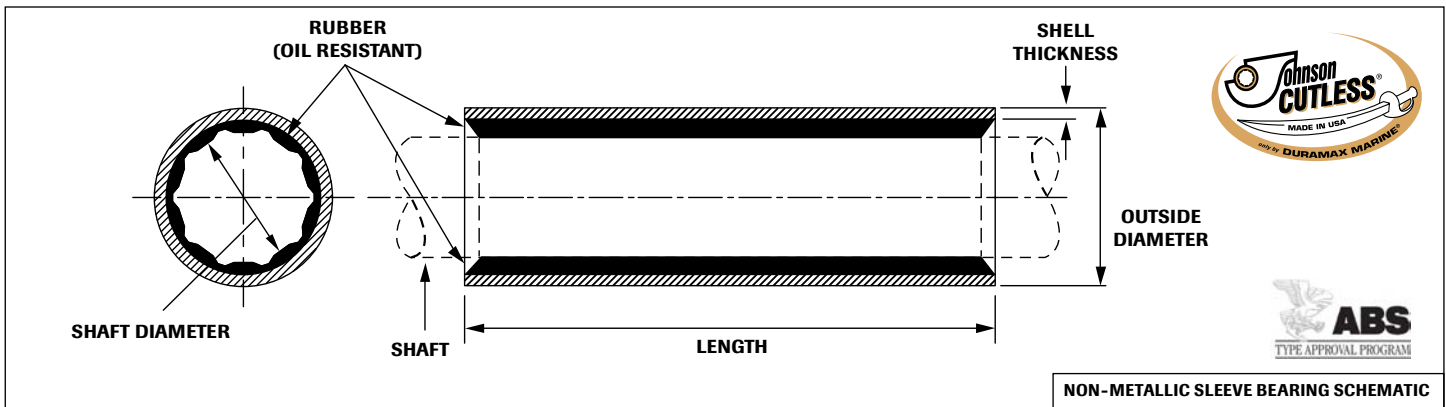

Part Number	Shaft Diameter (mm)	Outside Diameter (mm)	Length (mm)	Shell Thickness (mm)	Weight	
					lb.	kg.
870255700	25	40	100	2.54	0.30	0.1
870285700	28	42	112	2.35	0.40	0.2
870305700	30	45	120	3.07	0.40	0.2
870325700	32	45	128	3.07	0.50	0.2
870355700	35	50	140	3.07	0.50	0.2
870385700	38	55	152	3.07	0.60	0.3
870405700	40	55	160	3.07	0.60	0.3
870455700	45	65	180	3.30	0.90	0.4
870505700	50	70	200	3.25	1.10	0.5
870555700	55	75	220	2.58	1.30	0.6
870605700	60	80	240	3.25	1.60	0.7
870655700	65	85	260	2.81	1.80	0.8
870705700	70	90	280	4.75	2.00	0.9
870755700	75	95	300	3.05	2.50	1.1
870805700	80	100	320	3.16	2.60	1.2
870855700	85	105	340	3.17	3.00	1.4
870905700	90	110	360	4.76	3.40	1.5
870955700	95	115	380	4.50	4.00	1.8
871005700	100	125	400	3.76	4.60	2.1
871055700	105	130	420	4.51	5.20	2.4
871105700	110	135	440	4.51	6.00	2.7
871155700	115	145	460	4.24	7.60	3.4
871205700	120	155	480	6.06	8.60	3.9
871305700	130	170	520	5.63	13.00	5.9

Non-Metallic Sleeve Bearings

INCH SIZE SERIES



Johnson Cutless® Non-Metallic Sleeve Bearings feature a dense structure of engineered reinforced thermoset plastic. The specially compounded Nitrile Rubber is securely bonded to the shell with all tolerances maintained for proper lubrication. Being non-corrosive and inherently resistant to all known chemicals, oil and grease, as well as being anti-electrolytic, the Johnson Cutless® Non-Metallic Sleeve Bearings are ideally suited for installations wherever corrosion or electrolysis is a problem.

PRECAUTION: When shrink fitting of the bearing is required, chilling must be achieved by gradual cooling to not more than minus 20°F(-28°C) using freezer or regular ice (**DO NOT DRY ICE**). NOTE: Pounding or shocking the bearing while in the chilled state could cause the rubber to separate from the shell.

Approved Bearings: Johnson Cutless Non-Metallic Sleeve Bearings have full type approval from The American Bureau of Shipping.

Part Number	Code	Shaft Diameter Dimensions		Outside Diameter Dimensions		Length Dimensions		Shell Thickness Dimensions		Weight	
		inches	mm	inches	mm	inches	mm	inches	mm	lb.	kg.
870193700	ALDA	3/4	19.05	1 1/4	31.75	3	76.20	1/8	3.18	0.2	0.1
870223700	ALICE	7/8	22.23	1 1/4	31.75	3 1/2	88.90	3/64	1.19	0.2	0.1
870223701	ANNE	7/8	22.23	1 3/8	34.93	3 1/2	88.90	1/8	3.18	0.2	0.1
870223702	ARDELE	7/8	22.23	1 1/2	38.10	3 1/2	88.90	1/8	3.18	0.3	0.1
870253700	BABE	1	25.40	1 1/4	31.75	4	101.60	1/16	1.59	0.2	0.1
870253701	BECKY	1	25.40	1 3/8	34.93	4	101.60	3/64	1.19	0.2	0.1
870253702	BETTY	1	25.40	1 1/2	38.10	4	101.60	1/8	3.18	0.3	0.1
870253703	CANDY	1	25.40	1 5/8	41.28	4	101.60	1/8	3.18	0.3	0.1
870253704	CARLA	1	25.40	2	50.80	4	101.60	1/8	3.18	0.5	0.2
870293700	CEIL	1 1/8	28.58	1 1/2	38.10	4 1/2	114.30	3/64	1.19	0.3	0.1
870293701	CINDY	1 1/8	28.58	1 5/8	41.28	4 1/2	114.30	1/8	3.18	0.3	0.1
870293702	CONNIE	1 1/8	28.58	1 3/4	44.45	4 1/2	114.30	1/8	3.18	0.4	0.2
870293703	CORA	1 1/8	28.58	2	50.80	4 1/2	114.30	1/8	3.18	0.5	0.2
870323700	DEENA	1 1/4	31.75	1 1/2	38.10	5	127.00	3/64	1.19	0.2	0.1
870323701	DELLA	1 1/4	31.75	1 3/4	44.45	5	127.00	1/8	3.18	0.4	0.2
870323702	DORIS	1 1/4	31.75	2	50.80	5	127.00	1/8	3.18	0.6	0.3
870323703	DOTTY	1 1/4	31.75	2 1/8	53.98	5	127.00	1/8	3.18	0.6	0.3
870353700	EDNA	1 3/8	34.93	1 7/8	47.63	5 1/2	139.70	1/8	3.18	0.4	0.2
870353701	ELLEN	1 3/8	34.93	2	50.80	5 1/2	139.70	1/8	3.18	0.5	0.2
870353702	ELSA	1 3/8	34.93	2 1/8	53.98	5 1/2	139.70	1/8	3.18	0.6	0.3
870353703	ERMA	1 3/8	34.93	2 3/8	60.33	5 1/2	139.70	1/8	3.18	0.9	0.4
870383700	EVA	1 1/2	38.10	2	50.80	6	152.40	1/8	3.18	0.5	0.2
870383701	FANNY	1 1/2	38.10	2 3/8	60.33	6	152.40	1/8	3.18	0.9	0.4
870413700	FLO	1 5/8	41.28	2 1/8	53.98	6 1/2	165.10	1/8	3.18	0.6	0.3
870413701	FRAN	1 5/8	41.28	2 5/8	66.68	6 1/2	165.10	1/8	3.18	1.1	0.5
870453700	GLENDA	1 3/4	44.45	2 3/8	60.33	7	177.80	1/8	3.18	0.7	0.3
870453701	GLORIA	1 3/4	44.45	2 5/8	66.68	7	177.80	1/8	3.18	0.9	0.4
870483700	GWEN	1 7/8	47.63	2 5/8	66.68	7 1/2	190.50	1/8	3.18	0.8	0.4
870483701	HANNA	1 7/8	47.63	2 15/16	74.61	7 1/2	190.50	1/8	3.18	1.5	0.7
870513700	HAZEL	2	50.80	2 5/8	66.68	8	203.20	1/8	3.18	0.8	0.4
870513701	HELEN	2	50.80	3	76.20	8	203.20	1/8	3.18	1.5	0.7
870543700	HILDA	2 1/8	53.98	2 15/16	74.61	8 1/2	215.90	1/8	3.18	1.3	0.6
870543701	ILA	2 1/8	53.98	3 1/8	79.38	8 1/2	215.90	1/8	3.18	1.6	0.7
870573700	INEZ	2 1/4	57.15	2 15/16	74.61	9	228.60	1/8	3.18	1.2	0.5
870573701	INGRID	2 1/4	57.15	3 1/8	79.38	9	228.60	1/8	3.18	1.4	0.6
870573702	IRENE	2 1/4	57.15	3 3/8	85.73	9	228.60	1/8	3.18	1.6	0.7
870603700	JENNY	2 3/8	60.33	3 3/8	85.73	9 1/2	241.30	1/8	3.18	1.7	0.8
870643700	JOAN	2 1/2	63.50	3 1/8	79.38	10	254.00	1/8	3.18	1.4	0.6
870643701	JOSIE	2 1/2	63.50	3 3/8	85.73	10	254.00	1/8	3.18	2.0	0.9

All Bearings Shown Are Carried in Stock

NON-METALLIC SLEEVE BEARINGS - INCH

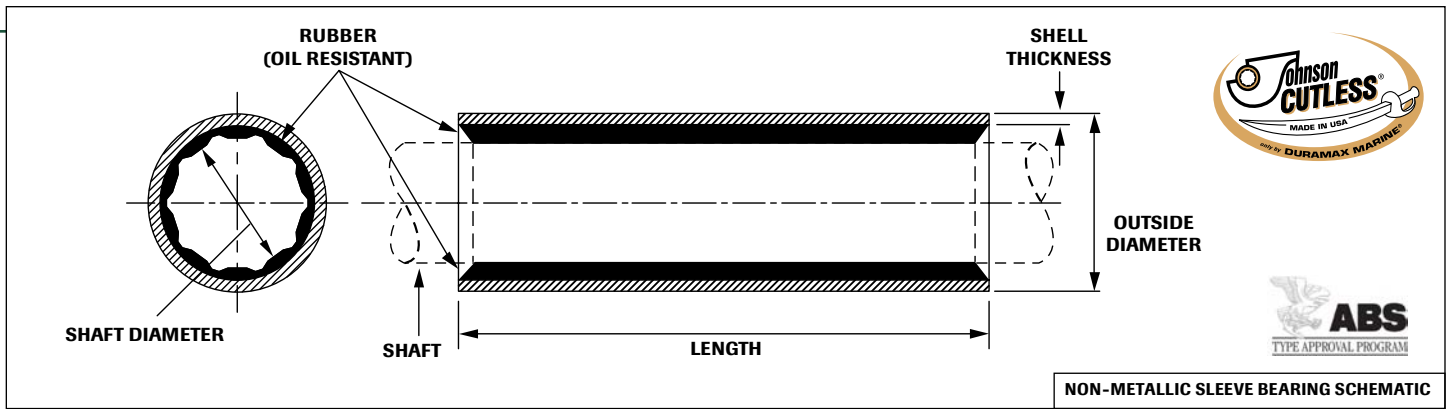

Part Number	Code	Shaft Diameter Dimensions		Outside Diameter Dimensions		Length Dimensions		Shell Thickness Dimensions		Weight	
		inches	mm	inches	mm	inches	mm	inches	mm	lb.	kg.
870673700	JOYCE	2 5/8	66.68	3 3/8	85.73	10 1/2	266.70	1/8	3.18	1.8	0.8
870703700	JUNE	2 3/4	69.85	3 3/8	85.73	11	279.40	1/8	3.18	1.6	0.7
870703701	KATHY	2 3/4	69.85	3 3/4	95.25	11	279.40	1/8	3.18	2.6	1.2
870733700	KELLY	2 7/8	73.03	3 3/4	95.25	11 1/2	292.10	1/8	3.18	2.5	1.1
870763700	KIM	3	76.20	3 3/4	95.25	12	304.80	1/8	3.18	2.4	1.1
870763701	LAURA	3	76.20	4	101.60	12	304.80	1/8	3.18	3.1	1.4
870803700	LENA	3 1/8	79.38	4 1/4	107.95	12 1/2	317.50	1/8	3.18	3.8	1.7
870833700	LINDA	3 1/4	82.55	4	101.60	13	330.20	1/8	3.18	2.7	1.2
870833701	LISA	3 1/4	82.55	4 1/4	107.95	13	330.20	1/8	3.18	3.5	1.6
870863700	LOIS	3 3/8	85.73	4 1/2	114.30	13 1/2	342.90	1/8	3.18	4.3	2.0
870893700	MANDY	3 1/2	88.90	4 1/4	107.95	14	355.60	1/8	3.18	3.1	1.4
870893701	MARIE	3 1/2	88.90	4 1/2	114.30	14	355.60	1/8	3.18	4.1	1.9
870923700	MARTHA	3 5/8	92.08	4 1/2	114.30	14 1/2	368.30	1/8	3.18	3.7	1.7
870953700	MARY	3 3/4	95.25	4 1/2	114.30	15	381.00	1/8	3.18	3.5	1.6
870953701	NANCY	3 3/4	95.25	5	127.00	15	381.00	3/16	4.76	5.9	2.7
870953702	NEVA	3 3/4	95.25	5 1/4	133.35	15	381.00	3/16	4.76	7.4	3.4
870993700	NORA	3 7/8	98.43	5 1/4	133.35	15 1/2	393.70	3/16	4.76	6.4	2.9
871023700	OLGA	4	101.60	5	127.00	16	406.40	3/16	4.76	5.3	2.4
871023701	OLIVE	4	101.60	5 1/4	133.35	16	406.40	3/16	4.76	6.4	2.9
871053700	OPAL	4 1/8	104.78	5 1/4	133.35	16 1/2	419.10	3/16	4.76	6.3	2.9
871083700	PAM	4 1/4	107.95	5 1/2	139.70	17	431.80	3/16	4.76	8.3	3.8
871113700	PANSY	4 3/8	111.13	5 3/4	146.05	17 1/2	444.50	3/16	4.76	8.8	4.0
871153700	PAULA	4 1/2	114.30	5 1/2	139.70	18	457.20	3/16	4.76	7.3	3.3
871153701	PENNY	4 1/2	114.30	5 3/4	146.05	18	457.20	3/16	4.76	8.8	4.0
871183700	RHODA	4 5/8	117.48	6 1/8	155.58	18 1/2	469.90	1/4	6.35	11.3	5.1
871213700	RINA	4 3/4	120.65	6 1/8	155.58	19	482.60	1/4	6.35	11.0	5.0
871243700	ROSE	4 7/8	123.83	6 1/8	155.58	19 1/2	495.30	1/4	6.35	10.3	4.7
871273700	RUTH	5	127.00	6 1/8	155.58	20	508.00	1/4	6.35	9.5	4.3
871273701	SALLY	5	127.00	6 1/2	165.10	20	508.00	1/4	6.35	13.0	5.9
871343700	SANDRA	5 1/4	133.35	6 3/4	171.45	21	533.40	1/4	6.35	14.0	6.4
871343701	SARAN	5 1/4	133.35	7	177.80	21	533.40	1/4	6.35	16.0	7.3
871373700	SUSAN	5 3/8	136.53	6 3/4	171.45	21 1/2	546.10	1/4	6.35	12.8	5.8
871373701	TONI	5 3/8	136.53	7	177.80	21 1/2	546.10	1/4	6.35	15.8	7.2
871403700	TRICIA	5 1/2	139.70	7	177.80	22	558.80	1/4	6.35	14.8	6.7
871433700	VERA	5 5/8	142.88	7	177.80	22 1/2	571.50	1/4	6.35	14.0	6.4
871463700	WANDA	5 3/4	146.05	7	177.80	23	584.20	1/4	6.35	14.8	6.7
871503700	WINNIE	5 7/8	149.23	7 1/2	190.50	24	609.60	1/4	6.35	18.0	8.2
871533700	ZELDA	6	152.40	7 1/2	190.50	24	609.60	1/4	6.35	18.8	8.5

All Bearings Shown Are Carried in Stock

NON-METALLIC SLEEVE BEARINGS - INCH

Solid Naval Brass Flanged Bearings

STRUT OR AFT STERN TUBE



FLANGE DRILLING
DIAGRAM ON PAGE 20

Johnson Cutless® Flanged Bearings are centrifugally cast naval brass with an integral flange for bolting to stern tube or strut housing to retain bearing and prevent rotation in housing. Specially formulated oil and chemical resistant nitrile rubber is securely bonded to the shell. Shells are heavy walled providing structural strength and can be step turned if desired. Flanges are furnished UN-DRILLED unless specified. See page 20 for Drilling Diagrams. For Split and Stepped Styles see [page 6](#).

PRECAUTION: When shrink fitting of the bearing is required, chilling must be achieved by gradual cooling to not more than minus 20°F(-28°C) using freezer or regular ice (**DO NOT DRY ICE**). NOTE: Pounding or shocking the bearing while in the chilled state could cause the rubber to separate from the shell.

Approved Bearings: Johnson Cutless® Naval Brass Flanged Bearings meet military specification MIL-B-17901 (Ships) Class II Full-Molded type and have full type approval from The American Bureau of Shipping.

Part Number	Code	Shaft Diameter		Outside Diameter		Length		Flange Diameter		Flange Thickness		Metal I.D.		Metal Thickness		Weight	
		inches	mm	inches	mm	inches	mm	inches	mm	inches	mm	inches	mm	inches	mm	lb.	kg.
860512102	BRACE	2	50.80	3	76.20	8	203.20	5	127.00	3/8	9.53	25/8	66.68	3/16	4.76	7	3.2
860642100	BROAD	2 1/2	63.50	3 3/8	85.73	10	254.00	5 1/2	139.70	3/8	9.53	3 1/8	79.38	1/8	3.18	9	4.1
860762100	CATCH	3	76.20	4 1/4	107.95	12	304.80	6 3/4	171.45	1/2	12.70	3 3/4	95.25	1/4	6.35	20	9.1
860832100	CLAMP	3 1/4	82.55	4 1/2	114.30	13	330.20	7	177.80	1/2	12.70	4	101.60	1/4	6.35	22	10.0
860892100	CRANK	3 1/2	88.90	4 3/4	120.65	12 1/2	317.50	6 3/4	171.45	1/2	12.70	4 1/4	107.95	1/4	6.35	21	9.5
860892101	CLEAR	3 1/2	88.90	4 7/8	123.65	14	355.60	7 3/8	187.33	1/2	12.70	4 1/4	107.95	5/16	7.94	29	13.2
860952100	CIVIL	3 3/4	95.25	5 1/4	133.35	15	381.00	7 3/4	196.85	1/2	12.70	4 5/8	117.48	5/16	7.94	32	14.5
861022100	DRAFT	4	101.60	5 1/2	139.70	16	406.40	8	203.20	1/2	12.70	4 7/8	123.83	5/16	7.94	36	16.3
861082100	DREAD	4 1/4	107.95	5 3/4	146.05	17	431.80	8 1/4	209.55	1/2	12.70	5 1/8	130.18	5/16	7.94	48	21.8
861112100	DANCE	4 3/8	111.13	6	152.40	22	558.80	8 7/8	225.43	1/2	12.70	5 3/8	136.53	5/16	7.94	64	29.0
861152100	DRINK	4 1/2	114.30	6	152.40	18	457.20	8 7/8	225.43	1/2	12.70	5 3/8	136.53	5/16	7.94	56	25.4
861212100	DROVE	4 3/4	120.65	6 1/4	158.75	19	482.60	9 1/8	231.78	1/2	12.70	5 3/8	136.53	5/16	7.94	62	28.1
861272100	EARTH	5	127.00	6 3/4	171.45	20	508.00	9 5/8	244.48	9/16	14.29	6	152.40	3/8	9.53	76	34.5
861342100	EASEL	5 1/4	133.35	6 7/8	174.63	21	533.40	9 7/8	250.83	9/16	14.29	6 1/8	155.58	3/8	9.53	81	36.7
861402100	ERASE	5 1/2	139.70	7 1/4	184.15	22	558.80	10 1/4	260.35	9/16	14.29	6 1/2	165.10	3/8	9.53	86	39.0
861462100	EVENT	5 3/4	146.05	7 1/4	184.15	23	584.20	10 1/4	260.35	9/16	14.29	6 1/2	165.10	3/8	9.53	88	39.9
861532100	FABLE	6	152.40	7 3/4	196.85	15	381.00	12 1/4	311.15	9/16	14.29	6 1/2	165.10	3/8	9.53	75	34.0
861532101	FAULT	6	152.40	7 3/4	196.85	24	609.60	11	279.40	9/16	14.29	7	177.80	3/8	9.53	101	45.8
—	—	6 1/8	155.58	7 7/8	200.03	22	558.80	10 1/2	266.70	9/16	14.29	7	177.80	3/8	9.53	—	—
861592100	FENCE	6 1/4	158.75	8	203.20	22 1/2	571.50	10 5/8	269.88	9/16	14.29	7 1/8	180.98	3/8	9.53	97	44.0
—	—	6 3/8	161.93	8 1/8	206.38	23	584.20	10 3/4	273.05	9/16	14.29	7 1/4	184.15	3/8	9.53	—	—
861662100	FLARE	6 1/2	165.10	8 3/8	212.73	23 1/2	596.90	11	279.40	9/16	14.29	7 3/8	187.33	7/16	11.13	113	51.3
861662101	FLEET	6 1/2	165.10	8 3/8	212.73	30	762.00	11	279.40	5/8	15.88	7 1/2	190.50	7/16	11.13	141	64.0
861692100	FLUTE	6 5/8	168.28	8 1/2	215.90	15	381.00	13 1/2	342.90	5/8	15.88	7 1/2	190.50	7/16	11.13	100	45.4
861692101	FLOOR	6 5/8	168.28	8 1/2	215.90	24	609.60	11 1/4	285.75	9/16	14.29	7 5/8	193.68	7/16	11.13	133	60.3
861692103	FRANK	6 5/8	168.28	8 5/8	219.08	24	609.60	11 1/4	285.75	9/16	14.29	7 5/8	193.68	3/8	9.53	130	59.0
861722100	FROZE	6 3/4	171.45	8 3/4	222.25	24	609.60	11 1/4	285.75	5/8	15.88	7 7/8	200.03	7/16	11.13	127	57.6
861722101	FANCY	6 3/4	171.45	8 3/4	222.25	24 1/2	622.30	11 3/8	288.93	9/16	14.29	7 7/8	200.03	7/16	11.13	135	61.2
861752100	FOUND	6 7/8	174.63	8 7/8	225.43	24 1/2	622.30	11 3/8	288.93	9/16	14.29	7 7/8	200.03	1/2	12.70	134	60.8
861752101	—	6 7/8	174.63	8 7/8	225.43	25	635.00	11 1/2	292.10	9/16	14.29	8	203.20	3/16	4.76	—	—
861782100	GAVEL	7	177.80	9	228.60	25 1/2	647.70	11 5/8	295.28	9/16	14.29	8 1/8	206.38	7/16	11.13	140	63.5
861782101	GLAND	7	177.80	9 1/8	231.78	25 1/2	647.70	11 5/8	295.28	9/16	14.29	8 1/8	206.38	1/2	12.70	154	69.9
—	—	7 1/8	180.98	9 1/8	231.78	25 1/2	647.70	11 3/4	298.45	9/16	14.29	8 1/4	209.55	7/16	11.13	—	—
861852100	GLASS	7 1/4	184.15	9 1/4	234.95	26 1/2	673.10	11 7/8	301.63	9/16	14.29	8 3/8	212.73	7/16	11.13	150	68.0
—	—	7 3/8	196.85	9 1/2	241.30	27	685.80	12 1/8	307.98	9/16	14.29	8 5/8	219.08	7/16	11.13	—	—
861912100	GLORY	7 1/2	190.50	9 5/8	244.48	17 1/2	444.50	14 1/2	368.30	1	25.40	8 3/4	222.25	7/16	11.13	129	58.5
861912101	GLOBE	7 1/2	190.50	9 5/8	244.48	27 1/2	698.50	12 3/4	323.85	9/16	14.29	8 3/4	222.25	7/16	11.13	160	72.6
—	—	7 5/8	193.68	9 3/4	247.65	28	711.20	12 3/8	314.33	9/16	14.29	8 3/4	222.25	1/2	12.70	—	—
861972100	GIPSY	7 3/4	196.85	9 7/8	250.83	28 1/2	723.90	12 1/2	317.50	9/16	14.29	8 7/8	225.43	1/2	12.70	180	81.7
—	—	7 7/8	200.03	10	254.00	29 1/2	749.30	12 5/8	320.68	9/16	14.29	9 1/8	231.78	7/16	11.13	—	—
862042101	HEART	8	203.20	10 1/4	260.35	29 1/2	749.30	13 1/4	336.55	5/8	15.88	9 1/2	241.30	3/8	9.53	166	75.3
862042102	HEDGE	8	203.20	10 1/2	266.70	29 1/2	749.30	13 1/4	336.55	5/8	15.88	9 1/2	241.30	1/2	12.70	210	95.3
—	—	8 1/8	206.38	10 3/8	263.53	30	762.00	13 3/8	339.73	5/8	15.88	9 3/8	238.13	1/2	12.70	—	—
862102100	HITCH	8 1/4	209.55	10 1/2	266.70	30 1/2	774.70	13 1/2	342.90	5/8	15.88	9 1/2	241.30	1/2	12.70	208	94.4
—	—	8 3/8	212.73	10 5/8	269.88	31	787.40	13 5/8	346.08	5/8	15.88	9 5/8	244.48	1/2	12.70	—	—
862172100	HOIST	8 1/2	215.90	10 3/4	273.05	31 1/2	800.10	13 3/4	349.25	5/8	15.88	9 3/4	247.65	1/2	12.70	215	97.5
—	—	8 5/8	219.08	10 7/8	276.23	32	812.80	13 7/8	352.43	5/8	15.88	9 7/8	250.83	1	25.40	—	—
862232100	HOVER	8 3/4	222.25	11	279.40	32 1/2	825.50	14	355.60	5/8	15.88	10	254.00	1/2	12.70	233	105.7
—	—	8 7/8	225.43	11 1/8	282.58	33	838.20	14 1/8	358.78	3/4	19.05	10 1/8	257.18	1/2	12.70	—	—
862292100	INFRA	9	228.60	11 1/4	285.75	33 1/2	850.90	14 1/4	361.95	3/4	19.05	10 1/4	260.35	1/2	12.70	254	115.2
862292101	IDEAL	9	228.60	11 1/2	292.10	33 3/8	847.73	15	381.00	3/4	19.05	10 1/4	260.35	5/8	15.88	301	136.5

NAVAL BRASS FLANGED BEARINGS

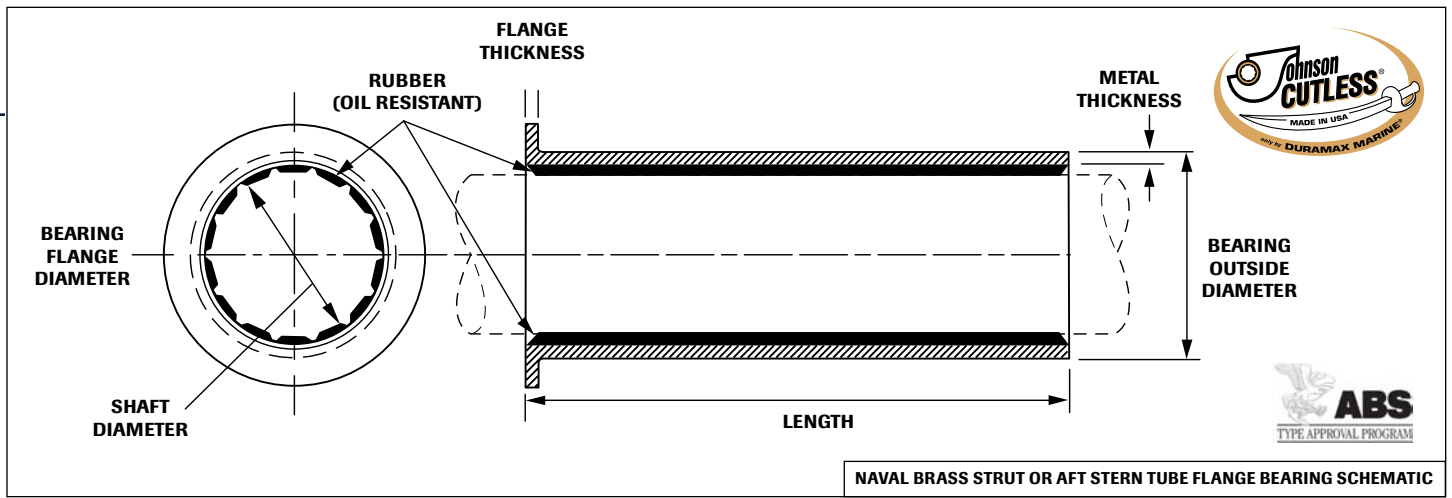

Part Number	Code	Shaft Diameter		Outside Diameter		Length		Flange Diameter		Flange Thickness		Metal I.D.		Metal Thickness		Weight	
		inches	mm	inches	mm	inches	mm	inches	mm	inches	mm	inches	mm	inches	mm	lb.	kg.
862332101	—	9 1/8	231.78	11 3/8	288.93	34	863.60	14 1/2	368.30	3/4	19.05	10 3/8	263.53	1/2	12.70	—	—
862332100	INNER	9 1/8	231.78	11 1/2	292.10	34 1/2	876.30	16 3/8	415.93	5/8	15.88	10 3/8	263.53	9/16	14.29	284	128.8
862362100	IRISH	9 1/4	234.95	11 1/2	292.10	34 1/2	876.30	14 5/8	371.48	11/16	17.46	10 1/2	266.70	1/2	12.70	260	117.9
862392100	—	9 3/8	238.13	11 5/8	295.28	35	889.00	14 3/4	374.65	3/4	19.05	10 5/8	269.88	1/2	12.70	—	—
862422100	INSET	9 1/2	241.30	11 3/4	298.45	35 1/2	901.70	14 7/8	377.83	3/4	19.05	10 3/4	273.05	1/2	12.70	274	124.3
862452100	—	9 5/8	244.48	11 7/8	301.63	36	914.40	15	381.00	3/4	19.05	10 7/8	276.23	1/2	12.70	—	—
862482100	IVORY	9 3/4	247.65	12 1/8	307.98	36 1/2	927.10	15 1/4	387.35	3/4	19.05	11	279.40	9/16	14.29	307	139.3
—	—	9 7/8	250.83	12 1/4	311.15	37	939.80	15 3/8	390.53	3/4	19.05	11 1/8	282.58	9/16	14.29	—	—
862552100	JEWEL	10	254.00	12 3/8	314.33	37 1/2	952.50	15 1/2	393.70	3/4	19.05	11 1/4	285.75	9/16	14.29	333	151.1
862582100	—	10 1/8	257.18	12 1/2	317.50	38	965.20	15 5/8	396.88	3/4	19.05	11 1/4	285.75	5/8	15.88	—	—
862612100	JETTY	10 1/4	260.35	12 5/8	320.68	38 1/2	977.90	15 7/8	403.23	3/4	19.05	11 1/2	292.10	9/16	14.29	352	159.7
—	—	10 3/8	263.53	12 3/4	323.85	39	990.60	16	406.40	3/4	19.05	11 5/8	295.28	9/16	14.29	—	—
862682100	JUMBO	10 1/2	266.70	12 7/8	327.03	39 1/2	1003.30	16 1/8	409.58	3/4	19.05	11 3/4	298.45	9/16	14.29	350	158.8
—	—	10 5/8	269.88	13	330.20	40	1016.00	16 1/4	412.75	3/4	19.05	11 7/8	301.63	9/16	14.29	—	—
862742100	JUDGE	10 3/4	273.05	13 1/8	333.38	40 1/2	1028.70	16 3/8	415.93	3/4	19.05	12	304.80	9/16	14.29	368	166.9
—	—	10 7/8	276.23	13 1/4	336.55	41	1041.40	17	431.80	3/4	19.05	12 1/8	307.98	9/16	14.29	—	—
862802100	KNOCK	11	279.40	13 1/2	342.90	41 1/2	1054.10	17 1/4	438.15	3/4	19.05	12 3/8	314.33	9/16	14.29	420	190.5
—	—	11 1/8	282.58	13 5/8	346.08	42	1066.80	17 3/8	441.33	3/4	19.05	12 1/2	317.50	9/16	14.29	—	—
826872100	KRAFT	11 1/4	285.75	13 3/4	349.25	42 1/2	1079.50	17 1/2	444.50	3/4	19.05	12 5/8	320.68	9/16	14.29	432	196.0
—	—	11 3/8	288.93	14	355.60	43	1092.20	17 3/4	450.85	3/4	19.05	12 3/4	323.85	5/8	15.88	—	—
862932101	KNEEL	11 1/2	292.10	14 1/8	358.78	43 1/2	1104.90	17 7/8	454.03	3/4	19.05	12 7/8	327.03	5/8	15.88	482	218.6
862932100	KNIFE	11 1/2	292.10	14 7/8	377.83	50 3/4	1289.10	20 1/4	514.35	1 1/4	31.75	12 7/8	327.03	1	25.40	860	390.1
862962100	—	11 5/8	295.28	14 1/4	361.95	44	1117.60	18	457.20	3/4	19.05	13	330.20	5/8	15.88	—	—
862992100	KNOTS	11 3/4	298.45	14 3/8	365.13	44 1/2	1130.30	18 1/8	460.38	3/4	19.05	13 1/8	333.38	5/8	15.88	502	227.7
—	—	11 7/8	301.63	14 1/2	368.30	45	1143.00	18 1/4	463.55	3/4	19.05	13 1/4	336.55	5/8	15.88	—	—
863062100	LABOR	12	304.80	14 3/4	374.65	45 1/2	1155.70	18 1/2	469.90	3/4	19.05	13 1/2	342.90	5/8	15.88	516	234.1
863092100	LOGAN	12 1/8	307.98	14 7/8	377.83	46	1168.40	18 5/8	473.08	3/4	19.05	13 5/8	346.08	5/8	15.88	—	—
863122100	LANCE	12 1/4	311.15	15	381.00	46 1/2	1181.10	18 3/4	476.25	3/4	19.05	13 3/4	349.25	5/8	15.88	539	244.5
—	LEASE	12 3/8	314.33	15 1/8	384.18	47	1193.80	18 7/8	479.43	3/4	19.05	13 7/8	352.43	5/8	15.88	—	—
863182100	LAYER	12 1/2	317.50	15 1/4	387.35	47 1/2	1206.50	19	482.60	3/4	19.05	14	355.60	5/8	15.88	554	251.3
863222100	LOGIC	12 5/8	320.68	15 3/8	390.53	48	1219.20	19 1/8	485.78	3/4	19.05	14 1/8	358.78	5/8	15.88	582	264.0
863252100	MILKY	12 3/4	323.85	15 1/2	393.70	48 1/2	1231.90	19 1/4	488.95	3/4	19.05	14 1/4	361.95	5/8	15.88	—	—
863282100	MUSIC	12 7/8	327.03	15 5/8	396.88	49	1244.60	19 3/8	492.13	3/4	19.05	14 3/8	365.13	5/8	15.88	—	—
863312100	MINCE	13	330.20	15 7/8	403.23	50	1270.00	19 5/8	498.48	7/8	22.23	14 1/2	368.30	11/16	17.46	674	305.7
863342100	MITTY	13 1/8	333.38	16	406.40	50 1/2	1282.70	19 3/4	501.65	7/8	22.23	14 5/8	371.48	11/16	17.46	710	322.1
863372100	MISTY	13 1/4	336.55	16 1/8	409.58	51	1295.40	19 7/8	504.83	7/8	22.23	14 3/4	374.65	11/16	17.46	—	—
863412100	NIFTY	13 3/8	339.73	16 1/4	412.75	51 1/2	1308.10	20	508.00	7/8	22.23	14 7/8	377.83	11/16	17.46	696	315.7
863442100	NIECE	13 1/2	342.90	16 3/8	415.93	52	1320.80	20 1/8	511.18	7/8	22.23	15	381.00	11/16	17.46	697	316.1
863472100	NOVEL	13 5/8	346.08	16 1/2	419.10	52 1/2	1333.50	20 1/4	514.35	7/8	22.23	15 1/8	384.18	11/16	17.46	—	—
863502100	ORTHA	13 3/4	349.25	16 5/8	422.28	53	1346.20	20 3/8	517.53	7/8	22.23	15 1/4	387.35	11/16	17.46	—	—
—	OGGLE	13 7/8	352.43	16 3/4	425.45	53 1/2	1358.90	20 1/2	520.70	7/8	22.23	15 3/8	390.53	11/16	17.46	—	—
863572100	OPERA	14	355.60	16 7/8	428.63	54	1371.60	20 5/8	523.88	7/8	22.23	15 1/2	393.70	11/16	17.46	735	333.4
—	PURSE	14 1/8	358.78	17	431.80	54 1/2	1384.30	20 3/4	527.05	7/8	22.23	15 5/8	396.88	11/16	17.46	—	—
—	POLAR	14 1/4	361.95	17 1/8	435.98	55	1397.00	20 7/8	530.23	7/8	22.23	15 3/4	400.05	11/16	17.46	—	—
863662100	POINT	14 3/8	365.13	17 1/4	438.15	55 1/2	1409.70	21	533.40	7/8	22.23	15 7/8	403.23	11/16	17.46	842	381.9
863692100	PRUNE	14 1/2	368.30	17 1/2	444.50	56	1422.40	21 1/4	539.75	7/8	22.23	16	406.40	3/4	19.05	852	386.5
—	PRICE	14 5/8	371.48	17 5/8	447.68	56 1/2	1435.10	21 3/8	542.93	7/8	22.23	16 1/8	409.58	3/4	19.05	—	—
—	PUNCH	14 3/4	374.65	17 3/4	450.85	57	1447.80	21 1/2	546.10	7/8	22.23	16 1/4	412.75	3/4	19.05	—	—
—	QUAKE	14 7/8	377.83	17 7/8	454.03	57 1/2	1460.50	21 5/8	549.28	7/8	22.23	16 3/8	415.93	3/4	19.05	—	—
863822100	QUIET	15	381.00	18	457.20	58	1473.20	21 3/4	552.45	7/8	22.23	16 1/2	419.10	3/4	19.05	905	410.5

NAVAL BRASS FLANGED BEARINGS

Solid Naval Brass Flanged Bearings

FORWARD STERN TUBE

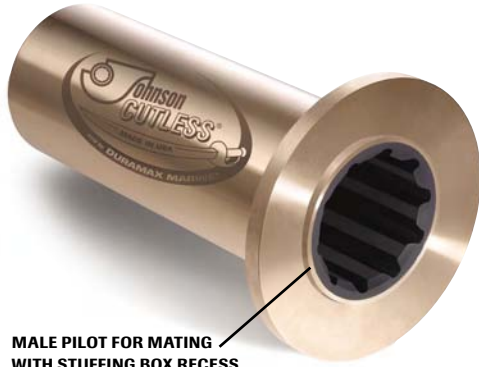

MALE PILOT FOR MATING WITH STUFFING BOX RECESS

Johnson Cutless Forward Stern Tube Flanged Bearings are made of centrifugally cast naval brass and feature a heavy metal wall and integral flange. The specially formulated nitrile rubber compound is securely bonded to metal shell and is chemical and oil resistant. The integral flange permits solid bolting of the bearing to stern tube stuffing box. The machined male pilot on the integral flange mates with the female recess of the stuffing box. Flanges are furnished UN-DRILLED unless specified. See page 21 for "Drilling Diagrams". For Split or Stepped styles see page 6.

PRECAUTION: When shrink fitting of the bearing is required, chilling must be achieved by gradual cooling to not more than minus 20°F(-28°C) using freezer or regular ice (**DO NOT DRY ICE**). NOTE: Pounding or shocking the bearing while in the chilled state could cause the rubber to separate from the shell.

Approved Bearings: Johnson Cutless® Naval Brass Flanged Bearings meet military specification MIL-B-17901 (Ships) Class II Full-Molded type and have full type approval from The American Bureau of Shipping.

Part Number	Code	Shaft Diameter (A) Dimensions		Outside Diameter (B) Dimensions		Length (C) Dimensions		Flange Diameter (D) Dimensions	
		inches	mm	inches	mm	inches	mm	inches	mm
860642180	212	2 1/2	63.50	3 3/8	85.73	10	254.00	6 1/4	158.75
860762180	300	3	76.20	4 1/4	107.95	12	304.80	7 1/2	190.50
860832180	314	3 1/4	82.55	4 1/2	114.30	13	330.20	7 1/2	190.50
860892180	312	3 1/2	88.90	4 7/8	123.83	14	355.60	8 1/8	206.38
860952180	334	3 3/4	95.25	5 1/4	133.35	15	381.00	8 1/8	206.38
861022180	400	4	101.60	5 1/2	139.70	16	406.40	8 5/8	219.08
861082180	414	4 1/4	107.95	5 3/4	146.05	17	431.80	8 5/8	219.08
861152180	412	4 1/2	114.30	6	152.40	18	457.20	9 3/8	238.13
861212180	434	4 3/4	120.65	6 1/4	158.75	19	482.60	9 3/8	238.13
861272180	500	5	127.00	6 3/4	171.45	20	508.00	10 1/8	257.18
861342181	514	5 1/4	133.35	6 7/8	174.63	21	533.40	10 1/8	257.18
861402180	512	5 1/2	139.70	7 1/4	184.15	22	558.80	10 5/8	269.88
861462180	534	5 3/4	146.05	7 1/4	184.15	23	584.20	10 5/8	269.88
861532180	600	6	152.40	7 3/4	196.85	15	381.00	11 3/8	288.93
—	618	6 1/8	155.58	7 7/8	200.03	15	381.00	12 1/4	311.15
861592180	614	6 1/4	158.75	7 7/8	200.03	15	381.00	11 3/8	288.93
—	638	6 3/8	161.93	8 1/8	206.38	15	381.00	12 5/8	320.68
861662180	612	6 1/2	165.10	8 3/8	212.73	15	381.00	13 1/2	342.90
861692180	FETCH	6 5/8	168.28	8 5/8	219.08	15	381.00	13 1/2	342.90
—	658	6 5/8	168.28	8 1/2	215.90	15	381.00	13 1/2	342.90
861722180	634	6 3/4	171.45	8 3/4	222.25	15	381.00	13 3/4	349.25
—	678	6 7/8	174.63	8 7/8	225.43	15	381.00	13 3/4	349.25
861782180	700	7	177.80	9	228.60	17 1/2	444.50	13 3/4	349.25
—	718	7 1/8	180.98	9 1/8	231.78	17 1/2	444.50	14 1/8	358.78
861852180	714	7 1/4	184.15	9 1/4	234.95	17 1/2	444.50	14 1/8	358.78
—	738	7 3/8	187.33	9 1/2	241.30	17 1/2	444.50	14 1/8	358.78
861912180	712	7 1/2	190.50	9 5/8	244.48	17 1/2	444.50	14 1/2	368.30
—	758	7 5/8	193.68	9 3/4	247.65	17 1/2	444.50	14 1/2	368.30
861972180	734	7 3/4	196.85	9 7/8	250.83	17 1/2	444.50	14 1/2	368.30
—	778	7 7/8	200.03	10	254.00	17 1/2	508.00	14 7/8	377.83
862042180	HARDY	8	203.20	10 1/4	260.35	20	508.00	14 7/8	377.83
—	818	8 1/8	206.38	10 3/8	263.53	20	508.00	14 7/8	377.83
862102180	814	8 1/4	209.55	10 1/2	266.70	20	508.00	15 1/4	387.35
—	838	8 3/8	212.73	10 5/8	269.88	20	508.00	15 1/4	387.35
862172180	812	8 1/2	215.90	10 3/4	273.05	20	508.00	15 1/4	387.35
—	858	8 5/8	219.08	10 7/8	276.23	20	508.00	15 5/8	396.88
862232180	834	8 3/4	222.25	11	279.40	20	508.00	15 5/8	396.88
—	878	8 7/8	225.43	11 1/8	282.58	20	571.50	15 5/8	396.88
862292180	900	9	228.60	11 1/4	285.75	22 1/2	571.50	16	406.40

NOTE: Dimensions for each size bearing continue across both pages.

NAVAL BRASS FLANGED BEARINGS

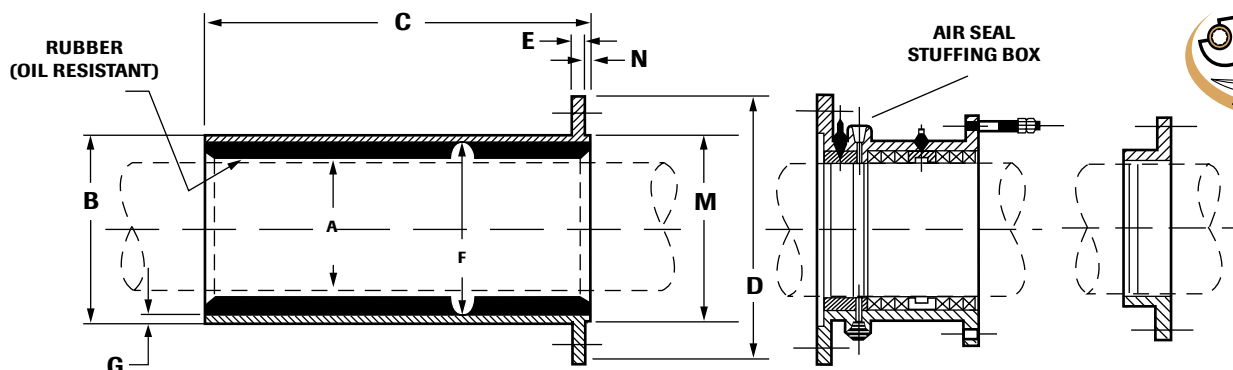

A SHAFT DIAMETER
B OUTSIDE DIAMETER
C LENGTH
D FLANGE DIAMETER
E FLANGE THICKNESS
F METAL I.D.
G METAL THICKNESS
M PILOT DIAMETER
N PILOT THICKNESS



NAVAL BRASS FORWARD STERN TUBE FLANGED BEARING SCHEMATIC

Flange Thickness (E) Dimensions		Metal I.D. (F) Dimensions		Metal Thickness (G) Dimensions		Pilot Diameter (M) Dimensions		Pilot Thickness (N) Dimensions		Weight	
inches	mm	inches	mm	inches	mm	inches	mm	inches	mm	lb.	kg.
3/8	9.53	3 1/8	79.38	1/8	3.18	4	101.60	3/16	4.76	12	5.4
1/2	12.70	3 3/4	95.25	1/4	6.35	4 3/4	120.65	3/16	4.76	21	9.5
1/2	12.70	4	101.60	1/4	6.35	4 3/4	120.65	3/16	4.76	24	10.9
1/2	12.70	4 1/4	107.95	5/16	7.94	5 1/4	133.35	3/16	4.76	38	17.2
1/2	12.70	4 5/8	117.48	5/16	7.94	5 1/4	133.35	3/16	4.76	43	19.5
1/2	12.70	4 7/8	123.83	5/16	7.94	5 3/4	146.05	3/16	4.76	48	21.8
1/2	12.70	5 1/8	130.18	5/16	7.94	5 3/4	146.05	3/16	4.76	52	23.6
1/2	12.70	5 3/8	136.53	5/16	7.94	6 1/2	165.10	3/16	4.76	58	26.3
1/2	12.70	5 5/8	142.88	5/16	7.94	6 1/2	165.10	3/16	4.76	61	27.7
9/16	14.29	6	152.40	3/8	9.53	7 1/4	184.15	3/16	4.76	75	34.0
9/16	14.29	6 1/8	155.58	3/8	9.53	7 1/4	184.15	3/16	4.76	79	35.8
9/16	14.29	6 1/2	165.10	3/8	9.53	7 3/4	196.85	3/16	4.76	90	40.8
9/16	14.29	6 1/2	165.10	3/8	9.53	7 3/4	196.85	3/16	4.76	92	41.7
9/16	14.29	7	177.80	3/8	9.53	8	203.20	3/8	9.53	75	34.0
9/16	14.29	7 1/8	180.98	3/8	9.53	8	203.20	3/8	9.53	—	—
9/16	14.29	7 1/8	180.98	3/8	9.53	8	203.20	3/8	9.53	77	34.9
9/16	14.29	7 3/8	187.33	3/8	9.53	8 3/8	212.73	3/8	9.53	—	—
5/8	15.88	7 1/2	190.50	7/16	11.11	8 5/8	219.08	3/8	9.53	91	41.3
5/8	15.88	7 5/8	193.68	1/2	12.70	8 5/8	219.08	3/8	9.53	104	47.2
5/8	15.88	7 5/8	193.68	7/16	11.11	8 5/8	219.08	3/8	9.53	—	—
5/8	15.88	7 7/8	200.03	7/16	11.11	9	228.60	3/8	9.53	99	44.9
5/8	15.88	8	203.20	7/16	11.11	9	228.60	3/8	9.53	—	—
5/8	15.88	8 1/8	206.38	7/16	11.11	9	228.60	3/8	9.53	116	52.6
5/8	15.88	8 1/4	209.55	7/16	11.11	9 5/8	244.48	3/8	9.53	—	—
5/8	15.88	8 3/8	212.73	7/16	11.11	9 5/8	244.48	3/8	9.53	122	55.3
5/8	15.88	8 5/8	219.08	7/16	11.11	9 5/8	244.48	3/8	9.53	—	—
5/8	15.88	8 3/4	222.25	7/16	11.11	10	254.00	3/8	9.53	123	55.8
5/8	15.88	8 7/8	225.43	7/16	11.11	10	254.00	3/8	9.53	—	—
5/8	15.88	8 7/8	225.43	1/2	12.70	10	254.00	3/8	9.53	126	57.2
5/8	15.88	9 1/8	231.78	7/16	11.11	10 3/8	263.53	3/8	9.53	—	—
5/8	15.88	9 1/4	234.95	1/2	12.70	10 3/8	263.53	3/8	9.53	145	65.8
5/8	15.88	9 3/8	238.13	1/2	12.70	10 3/8	263.53	3/8	9.53	—	—
5/8	15.88	9 1/2	241.30	1/2	12.70	10 3/4	273.05	3/8	9.53	157	71.2
5/8	15.88	9 5/8	244.48	1/2	12.70	10 3/4	273.05	3/8	9.53	162	73.5
5/8	15.88	9 3/4	247.65	1/2	12.70	10 3/4	273.05	3/8	9.53	162	73.5
3/4	19.05	9 7/8	250.83	1/2	12.70	11 1/8	282.58	3/8	9.53	—	—
3/4	19.05	10	254.00	1/2	12.70	11 1/8	282.58	3/8	9.53	170	77.1
3/4	19.05	10 1/8	257.18	1/2	12.70	11 1/8	282.58	3/8	9.53	—	—
3/4	19.05	10 1/4	260.35	1/2	12.70	11 1/2	292.10	3/8	9.53	193	87.5

NAVAL BRASS FLANGED BEARINGS

SOLID Flanged Bearings – Forward Stern Tube FULL MOLDED TYPE, continued on next page

Solid Naval Brass Flanged Bearings

FORWARD STERN TUBE

Continued



MALE PILOT FOR MATING WITH STUFFING BOX RECESS

The Solid Flanged Stern Tube Bearing is made of centrifugally cast naval brass and features a heavy wall and integral flange. The specially formulated and compounded nitrile rubber which is securely bonded to shell is chemical and oil resistant. The integral flange permits solid bolting of the bearing to stern tube and stuffing box. The machined male pilot on the bearing flange mates with the female recess of the stuffing box. Flanges are furnished UN-DRILLED unless specified. See page 20 for "Drilling Diagrams". For Split or Stepped styles see page 6.

PRECAUTION: When shrink fitting of the bearing is required, chilling must be achieved by gradual cooling to not more than minus 20°F(-28°C) using freezer or regular ice (**DO NOT DRY ICE**). NOTE: Pounding or shocking the bearing while in the chilled state could cause the rubber to separate from the shell.

Approved Bearings: Johnson Cutless® Naval Brass Flanged Bearings meet military specification MIL-B-17901 (Ships) Class II Full-Molded type and have full type approval from The American Bureau of Shipping.

Part Number	Code	Shaft Diameter (A)		Outside Diameter (B)		Length (C)		Flange Diameter (D)	
		Dimensions		Dimensions		Dimensions		Dimensions	
		inches	mm	inches	mm	inches	mm	inches	mm
—	918	9 1/8	231.78	11 3/8	288.93	22 1/2	571.50	16	406.40
862362180	INLET	9 1/4	234.95	11 1/2	292.10	22 1/2	571.50	16	406.40
—	938	9 3/8	238.13	11 5/8	295.28	22 1/2	571.50	16 3/8	415.93
862422180	912	9 1/2	241.30	11 3/4	298.45	22 1/2	571.50	16 3/8	415.93
862452182	958	9 5/8	244.48	11 7/8	301.63	22 1/2	571.50	16 3/8	415.93
862482180	934	9 3/4	247.65	12 1/8	307.98	22 1/2	571.50	16 7/8	428.63
862522180	978	9 7/8	250.83	12 1/4	311.15	22 1/2	571.50	16 7/8	428.63
862552180	1000	10	254.00	12 3/8	314.33	25	635.00	16 7/8	428.63
—	1018	10 1/8	257.18	12 1/2	317.50	25	635.00	17 7/8	454.03
862612180	1014	10 1/4	260.35	12 5/8	320.68	25	635.00	17 7/8	454.03
—	1038	10 3/8	263.53	12 3/4	323.85	25	635.00	17 7/8	454.03
862682180	1012	10 1/2	266.70	12 7/8	327.03	25	635.00	18 1/4	463.55
—	1058	10 5/8	269.88	13	330.20	25	635.00	18 1/4	463.55
862742180	JOLLY	10 3/4	273.05	13 1/8	333.38	25	635.00	18 1/4	463.55
—	1078	10 7/8	276.23	13 1/4	336.55	25	635.00	18 5/8	473.08
862802180	KETCH	11	279.40	13 1/2	342.90	27 1/2	698.50	18 5/8	473.08
—	1118	11 1/8	282.58	13 5/8	346.08	27 1/2	698.50	18 5/8	473.08
862872180	1114	11 1/4	285.75	13 3/4	349.25	27 1/2	698.50	19	482.60
—	1138	11 3/8	288.93	14	355.60	27 1/2	698.50	19	482.60
862932180	1112	11 1/2	292.10	14 1/8	358.78	27 1/2	698.50	19	482.60
—	1158	11 5/8	295.28	14 1/4	361.95	27 1/2	698.50	19 3/8	492.13
862992180	1134	11 3/4	298.45	14 3/8	365.13	27 1/2	698.50	19 3/8	492.13
—	1178	11 7/8	301.63	14 1/2	368.30	27 1/2	698.50	19 3/8	492.13
863062180	1200	12	304.80	14 3/4	374.65	30	762.00	19 3/4	501.65
863092180	1218	12 1/8	307.98	14 7/8	377.83	30	762.00	19 3/4	501.65
863122180	1214	12 1/4	311.15	15	381.00	30	762.00	19 3/4	501.65
863152180	1238	12 3/8	314.33	15 1/8	384.18	30	762.00	20 1/8	511.18
863182180	1212	12 1/2	317.50	15 1/4	387.35	30	762.00	20 1/8	511.18
863222180	1258	12 5/8	320.68	15 3/8	390.53	30	762.00	20 1/8	511.18
—	1234	12 3/4	323.85	15 1/2	393.70	30	762.00	20 1/2	520.70
—	1278	12 7/8	327.03	15 5/8	396.88	30	762.00	20 1/2	520.70
—	1300	13	330.20	15 7/8	403.23	32 1/2	825.50	20 1/2	520.70
—	1318	13 1/8	333.38	16	406.40	32 1/2	825.50	21	533.40
—	1314	13 1/4	336.55	16 1/8	409.58	32 1/2	825.50	21	533.40
—	1338	13 3/8	339.73	16 1/4	412.75	32 1/2	825.50	21	533.40
863442181	1312	13 1/2	342.90	16 3/8	415.93	32 1/2	825.50	21 3/8	542.93
863472180	1358	13 5/8	346.08	16 1/2	419.10	32 1/2	825.50	21 3/8	542.93
—	1334	13 3/4	349.25	16 5/8	422.28	32 1/2	825.50	21 3/8	542.93
—	1378	13 7/8	352.43	16 3/4	425.45	32 1/2	825.50	21 3/4	552.45
—	1400	14	355.60	16 7/8	428.63	35	889.00	21 3/4	552.45
—	1418	14 1/8	358.78	17	431.80	35	889.00	21 3/4	552.45
—	1414	14 1/4	361.95	17 1/8	434.98	35	889.00	22 1/8	561.98
—	1438	14 3/8	365.13	17 1/4	438.15	35	889.00	22 1/8	561.98
—	1412	14 1/2	368.30	17 1/2	444.50	35	889.00	22 1/8	561.98
—	1458	14 5/8	371.48	17 5/8	447.68	35	889.00	22 1/2	571.50
—	1434	14 3/4	374.65	17 3/4	450.85	35	889.00	22 1/2	571.50
—	1478	14 7/8	377.83	17 7/8	454.03	35	889.00	22 3/4	577.85
—	1500	15	381.00	18	457.20	35	889.00	22 3/4	577.85

NOTE: Dimensions for each size bearing continue across page.

NAVAL BRASS FLANGED BEARINGS

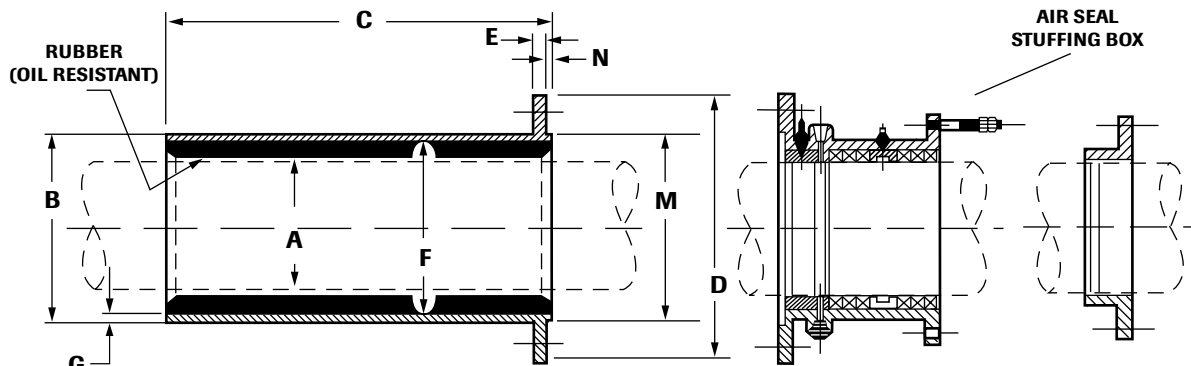

A SHAFT DIAMETER **D FLANGE DIAMETER** **G METAL THICKNESS**
B OUTSIDE DIAMETER **E FLANGE THICKNESS** **M PILOT DIAMETER**
C LENGTH **F METAL I.D.** **N PILOT THICKNESS**

NAVAL BRASS FORWARD STERN TUBE FLANGED BEARING SCHEMATIC

Flange Thickness (E) Dimensions		Metal I.D. (F) Dimensions		Metal Thickness (G) Dimensions		Pilot Diameter (M) Dimensions		Pilot Thickness (N) Dimensions		Weight	
inches	mm	inches	mm	inches	mm	inches	mm	inches	mm	lb.	kg.
3/4	19.05	10 3/8	263.53	1/2	12.70	11 1/2	292.10	3/8	9.53	200	90.7
3/4	19.05	10 1/2	266.70	1/2	12.70	11 1/2	292.10	3/8	9.53		
3/4	19.05	10 5/8	269.88	1/2	12.70	11 7/8	301.63	3/8	9.53		
3/4	19.05	10 3/4	273.05	1/2	12.70	11 7/8	301.63	3/8	9.53	205	17.2
3/4	19.05	10 7/8	276.23	1/2	12.70	11 7/8	301.63	3/8	9.53	217	98.4
3/4	19.05	11	279.40	9/16	14.29	12 3/8	314.33	3/8	9.53		
3/4	19.05	11 1/8	282.58	9/16	14.29	12 3/8	314.33	3/8	9.53		
3/4	19.05	11 1/4	285.75	9/16	14.29	12 3/8	314.33	3/8	9.53	240	108.9
3/4	19.05	11 3/8	288.93	9/16	14.29	12 3/4	323.85	3/8	9.53		
3/4	19.05	11 1/2	292.10	9/16	14.29	12 3/4	323.85	3/8	9.53		
3/4	19.05	11 5/8	295.28	9/16	14.29	12 3/4	323.85	3/8	9.53	244	110.7
3/4	19.05	11 3/4	298.45	9/16	14.29	13 1/8	333.38	3/8	9.53		
3/4	19.05	11 7/8	301.63	9/16	14.29	13 1/8	333.38	3/8	9.53		
3/4	19.05	12	304.80	9/16	14.29	13 1/8	333.38	3/8	9.53	250	113.4
3/4	19.05	12 1/8	307.95	9/16	14.29	13 1/2	342.90	3/8	9.53		
3/4	19.05	12 3/8	314.33	9/16	14.29	13 1/2	342.90	3/8	9.53		
3/4	19.05	12 1/2	317.50	9/16	14.29	13 1/2	342.90	3/8	9.53	300	136.1
3/4	19.05	12 5/8	320.68	9/16	14.29	13 7/8	352.43	3/8	9.53		
3/4	19.05	12 3/4	323.85	5/8	15.88	13 7/8	352.43	3/8	9.53		
3/4	19.05	12 7/8	327.03	5/8	15.88	13 7/8	352.43	3/8	9.53	312	141.5
3/4	19.05	13	330.20	5/8	15.88	14 1/8	358.78	3/8	9.53		
3/4	19.05	13 1/8	333.38	5/8	15.88	14 1/8	358.78	3/8	9.53		
3/4	19.05	13 1/4	336.55	5/8	15.88	14 1/8	358.78	3/8	9.53	335	152.0
3/4	19.05	13 1/2	342.90	5/8	15.88	14 1/2	368.30	3/8	9.53		
3/4	19.05	13 5/8	346.08	5/8	15.88	14 1/2	368.30	3/8	9.53		
3/4	19.05	13 3/4	349.25	5/8	15.88	14 1/2	368.30	3/8	9.53	360	163.3
7/8	22.23	13 7/8	352.43	5/8	15.88	15 1/8	384.18	3/8	9.53		
7/8	22.23	14	355.60	5/8	15.88	15 1/8	384.18	3/8	9.53		
7/8	22.23	14 1/8	358.78	5/8	15.88	15 1/8	384.18	3/8	9.53	394	178.7
7/8	22.23	14 1/4	361.95	5/8	15.88	15 1/2	393.70	3/8	9.53		
7/8	22.23	14 3/8	365.13	5/8	15.88	15 1/2	393.70	3/8	9.53		
7/8	22.23	14 1/2	368.30	11/16	17.46	15 1/2	393.70	3/8	9.53	—	—
7/8	22.23	14 5/8	371.48	11/16	17.46	15 3/4	400.05	3/8	9.53		
7/8	22.23	14 3/4	374.65	11/16	17.46	15 3/4	400.05	3/8	9.53		
7/8	22.23	14 7/8	377.83	11/16	17.46	15 3/4	400.05	3/8	9.53	—	—
7/8	22.23	15	381.00	11/16	17.46	16 1/4	412.75	3/8	9.53		
7/8	22.23	15 1/8	384.18	11/16	17.46	16 1/4	412.75	3/8	9.53		
7/8	22.23	15 1/4	387.35	11/16	17.46	16 1/4	412.75	3/8	9.53	—	—
7/8	22.23	15 3/8	390.53	11/16	17.46	16 5/8	422.28	3/8	9.53		
7/8	22.23	15 1/2	393.70	11/16	17.46	16 5/8	422.28	3/8	9.53		
7/8	22.23	15 5/8	396.88	11/16	17.46	16 5/8	422.28	3/8	9.53	—	—
7/8	22.23	15 3/4	400.05	11/16	17.46	17 1/4	438.15	3/8	9.53		
7/8	22.23	15 7/8	403.23	11/16	17.46	17 1/4	438.15	3/8	9.53		
7/8	22.23	16	406.40	3/4	19.05	17 1/4	438.15	3/8	9.53	—	—
7/8	22.23	16 1/8	409.58	3/4	19.05	17 1/2	444.50	3/8	9.53		
7/8	22.23	16 1/4	412.75	3/4	19.05	17 1/2	444.50	3/8	9.53		
7/8	22.23	16 3/8	415.93	3/4	19.05	17 3/4	450.85	3/8	9.53	—	—
7/8	22.23	16 1/2	419.10	3/4	19.05	17 3/4	450.85	3/8	9.53		

NAVAL BRASS FLANGED BEARINGS

Flanged Bearing Drilling Diagram

STRUT OR AFT STERN TUBE BEARINGS

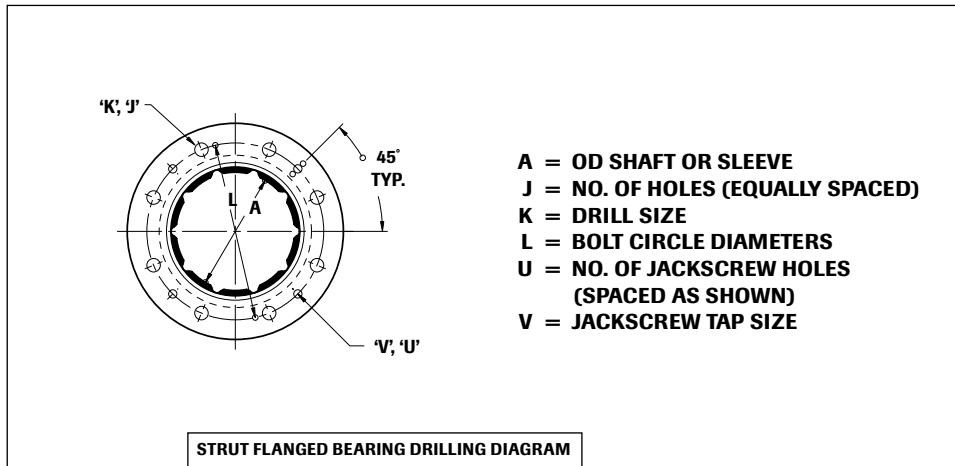

ALL DIMENSIONS IN INCHES

STRUT OR AFT STERN TUBE												
OD SHAFT OR SLEEVE	NO. OF HOLES	DRILL SIZE	BOLT CIRCLE DIAMETERS	NO. OF JACKSCREW	JACKSCREW TAP SIZE		OD SHAFT OR SLEEVE	NO. OF HOLES	DRILL SIZE	BOLT CIRCLE DIAMETERS	NO. OF JACKSCREW	JACKSCREW TAP SIZE
A	J	K	L	U	V		A	J	K	L	U	V
6	6	11/16	9	4	1/2		10 1/2	8	13/16	14 1/4	4	3/4
6 1/8	6	11/16	9 1/8	4	1/2		10 5/8	8	13/16	14 3/8	4	3/4
6 1/4	6	11/16	9 1/4	4	1/2		10 3/4	8	13/16	14 1/2	4	3/4
6 3/8	6	11/16	9 3/8	4	1/2		10 7/8	8	15/16	14 7/8	4	3/4
6 1/2	8	11/16	9 5/8	4	1/2		11	8	15/16	15 1/8	4	3/4
6 5/8	8	11/16	9 3/4	4	1/2		11 1/8	8	15/16	15 1/4	4	3/4
6 3/4	8	11/16	10	4	1/2		11 1/4	8	15/16	15 3/8	4	3/4
6 7/8	8	11/16	10 1/8	4	1/2		11 3/8	10	15/16	15 5/8	4	3/4
7	8	11/16	10 1/4	4	5/8		11 1/2	10	15/16	15 3/4	4	3/4
7 1/8	8	11/16	10 3/8	4	5/8		11 5/8	10	15/16	15 7/8	4	3/4
7 1/4	8	11/16	10 1/2	4	5/8		11 3/4	10	15/16	16	4	3/4
7 3/8	8	11/16	10 3/4	4	5/8		11 7/8	10	15/16	16 1/8	4	3/4
7 1/2	8	11/16	10 7/8	4	5/8		12	10	15/16	16 3/8	4	3/4
7 5/8	8	11/16	11	4	5/8		12 1/8	10	15/16	16 1/2	4	3/4
7 3/4	8	11/16	11 1/8	4	5/8		12 1/4	10	15/16	16 5/8	4	3/4
7 7/8	8	11/16	11 1/4	4	5/8		12 3/8	10	15/16	16 3/4	4	3/4
8	8	13/16	11 5/8	4	5/8		12 1/2	10	15/16	16 7/8	4	3/4
8 1/8	8	13/16	11 3/4	4	5/8		12 5/8	10	15/16	17	4	3/4
8 1/4	8	13/16	11 7/8	4	5/8		12 3/4	10	15/16	17 1/8	4	3/4
8 3/8	8	13/16	12	4	5/8		12 7/8	10	15/16	17 1/4	4	3/4
8 1/2	8	13/16	12 1/8	4	5/8		13	10	15/16	17 1/2	4	7/8
8 5/8	8	13/16	12 1/4	4	5/8		13 1/8	10	15/16	17 5/8	4	7/8
8 3/4	8	13/16	12 3/8	4	5/8		13 1/4	10	15/16	17 3/4	4	7/8
8 7/8	8	13/16	12 1/2	4	5/8		13 3/8	10	15/16	17 7/8	4	7/8
9	8	13/16	12 5/8	4	3/4		13 1/2	12	15/16	18	4	7/8
9 1/8	8	13/16	12 3/4	4	3/4		13 5/8	12	15/16	18 1/8	4	7/8
9 1/4	8	13/16	12 7/8	4	3/4		13 3/4	12	15/16	18 1/4	4	7/8
9 3/8	8	13/16	13	4	3/4		13 7/8	12	15/16	18 3/8	4	7/8
9 1/2	8	13/16	13 1/8	4	3/4		14	12	15/16	18 1/2	4	7/8
9 5/8	8	13/16	13 1/4	4	3/4		14 1/8	12	15/16	18 5/8	4	7/8
9 3/4	8	13/16	13 1/2	4	3/4		14 1/4	12	15/16	18 3/4	4	7/8
9 7/8	8	13/16	13 5/8	4	3/4		14 3/8	12	15/16	18 7/8	4	7/8
10	8	13/16	13 3/4	4	3/4		14 1/2	12	15/16	19 1/8	4	7/8
10 1/8	8	15/16	13 7/8	4	3/4		14 5/8	12	15/16	19 1/4	4	7/8
10 1/4	8	15/16	14	4	3/4		14 3/4	12	15/16	19 3/8	4	7/8
10 3/8	8	15/16	14 1/8	4	3/4		14 7/8	12	15/16	19 1/2	4	7/8
							15	12	15/16	19 5/8	4	7/8

FORWARD STERN TUBE BEARINGS

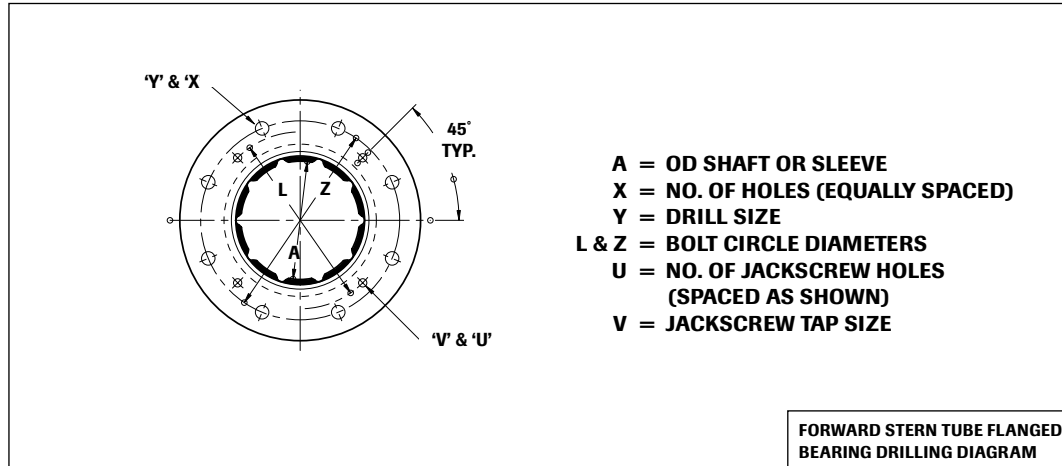

ALL DIMENSIONS IN INCHES

FORWARD STERN TUBE														
OD SHAFT OR SLEEVE	NO. OF HOLES	DRILL SIZE	BOLT CIRCLE DIAMETERS	BOLT CIRCLE DIAMETERS	NO. OF JACKSCREW	JACKSCREW TAP SIZE		OD SHAFT OR SLEEVE	NO. OF HOLES	DRILL SIZE	BOLT CIRCLE DIAMETERS	BOLT CIRCLE DIAMETERS	NO. OF JACKSCREW	JACKSCREW TAP SIZE
A	X	Y	Z	L	U	V		A	X	Y	Z	L	U	V
6	8	11/16	10 1/8	9	4	1/2		10 1/2	8	15/16	16 1/8	14 1/4	4	3/4
6 1/8	8	11/16	10 1/8	9 1/8	4	1/2		10 5/8	8	15/16	16 1/8	14 3/8	4	3/4
6 1/4	8	11/16	10 1/8	9 1/4	4	1/2		10 3/4	8	15/16	16 1/8	14 1/2	4	3/4
6 3/8	8	11/16	10 1/8	9 3/8	4	1/2		10 7/8	8	15/16	16 1/2	14 7/8	4	3/4
6 1/2	8	13/16	11 3/8	9 5/8	4	1/2		11	8	15/16	16 1/2	15 1/8	4	3/4
6 5/8	8	13/16	11 3/8	9 3/4	4	1/2		11 1/8	8	15/16	16 1/2	15 1/4	4	3/4
6 3/4	8	13/16	12	10	4	1/2		11 1/4	8	15/16	16 7/8	15 3/8	4	3/4
6 7/8	8	13/16	12	10 1/8	4	1/2		11 3/8	8	15/16	16 7/8	15 5/8	4	3/4
7	8	13/16	12	10 1/4	4	5/8		11 1/2	8	15/16	16 7/8	15 3/4	4	3/4
7 1/8	8	13/16	12 3/8	10 3/8	4	5/8		11 5/8	12	15/16	17 1/4	15 7/8	4	3/4
7 1/4	8	13/16	12 3/8	10 1/2	4	5/8		11 3/4	12	15/16	17 1/4	16	4	3/4
7 3/8	8	13/16	12 3/8	10 3/4	4	5/8		11 7/8	12	15/16	17 1/4	16 1/8	4	3/4
7 1/2	8	13/16	12 3/4	10 7/8	4	5/8		12	12	15/16	17 5/8	16 3/8	4	3/4
7 5/8	8	13/16	12 3/4	11	4	5/8		12 1/8	12	15/16	17 5/8	16 1/2	4	3/4
7 3/4	8	13/16	12 3/4	11 1/8	4	5/8		12 1/4	12	15/16	17 5/8	16 5/8	4	3/4
7 7/8	8	13/16	13 1/8	11 1/4	4	5/8		12 3/8	12	15/16	18	16 3/4	4	3/4
8	8	13/16	13 1/8	11 5/8	4	5/8		12 1/2	12	15/16	18	16 7/8	4	3/4
8 1/8	8	13/16	13 1/8	11 3/4	4	5/8		12 5/8	12	15/16	18	17	4	3/4
8 1/4	8	13/16	13 1/2	11 7/8	4	5/8		12 3/4	12	15/16	18 3/8	17 1/8	4	3/4
8 3/8	8	13/16	13 1/2	12	4	5/8		12 7/8	12	15/16	18 3/8	17 1/4	4	3/4
8 1/2	8	13/16	13 1/2	12 1/8	4	5/8		13	12	15/16	18 3/8	17 1/2	4	7/8
8 5/8	8	13/16	13 7/8	12 1/4	4	5/8		13 1/8	12	15/16	18 7/8	17 5/8	4	7/8
8 3/4	8	13/16	13 7/8	12 3/8	4	5/8		13 1/4	12	15/16	18 7/8	17 3/4	4	7/8
8 7/8	8	13/16	13 7/8	12 1/2	4	5/8		13 3/8	12	15/16	18 7/8	17 7/8	4	7/8
9	8	13/16	14 1/4	12 5/8	4	3/4		13 1/2	12	15/16	19 1/4	18	4	7/8
9 1/8	8	13/16	14 1/4	12 3/4	4	3/4		13 5/8	12	15/16	19 1/4	18 1/8	4	7/8
9 1/4	8	13/16	14 1/4	12 7/8	4	3/4		13 3/4	12	15/16	19 1/4	18 1/4	4	7/8
9 3/8	8	13/16	14 5/8	13	4	3/4		13 7/8	12	15/16	19 5/8	18 3/8	4	7/8
9 1/2	8	13/16	14 5/8	13 1/8	4	3/4		14	12	15/16	19 5/8	18 1/2	4	7/8
9 5/8	8	13/16	14 5/8	13 1/4	4	3/4		14 1/8	12	15/16	19 5/8	18 5/8	4	7/8
9 3/4	8	13/16	15	13 1/2	4	3/4		14 1/4	12	15/16	20	18 3/4	4	7/8
9 7/8	8	13/16	15	13 5/8	4	3/4		14 3/8	12	15/16	20	18 7/8	4	7/8
10	8	13/16	15	13 3/4	4	3/4		14 1/2	12	15/16	20	19 1/8	4	7/8
10 1/8	8	15/16	15 3/4	13 7/8	4	3/4		14 5/8	12	15/16	20 3/8	19 1/4	4	7/8
10 1/4	8	15/16	15 3/4	14	4	3/4		14 3/4	12	15/16	20 3/8	19 3/8	4	7/8
10 3/8	8	15/16	15 3/4	14 1/8	4	3/4		14 7/8	12	15/16	20 5/8	19 1/2	4	7/8
								15	12	15/16	20 5/8	19 5/8	4	7/8

FLANGED BEARING DRILLING DIAGRAM

Rudder Bushings

DX490



DX490 Rudder Bushings are molded from a 70 Scale D, Durometer, Nitrile Rubber Compound, formulated to withstand the rugged "impact" service encountered in ship's rudder steering systems. They possess high rigidity for maximum dimensional stability while still retaining a degree of resiliency required to dampen peak shock loads.

DX490 Rudder Bushings are homogenous cylinders molded with longitudinal lubrication grooves. Grease, oil and water serve equally well as lubricants. The DX490 Rudder Bushing is resistant to deterioration by hydrocarbons, acids, salt water corrosion and electrolysis.

CAUTION: DX490 Rudder Bushings are supplied with molded I.D. and O.D. dimensions which allow ample material for finish machining. However, when finish boring I.D. dimensions do not remove more than 70% of the lubricant groove depth.

IMPORTANT: In addition to interference press fit, **DX490** Rudder Bushings must be mechanically secured with set screws or other locking devices to prevent movement during operation and the expected operating temperature range.

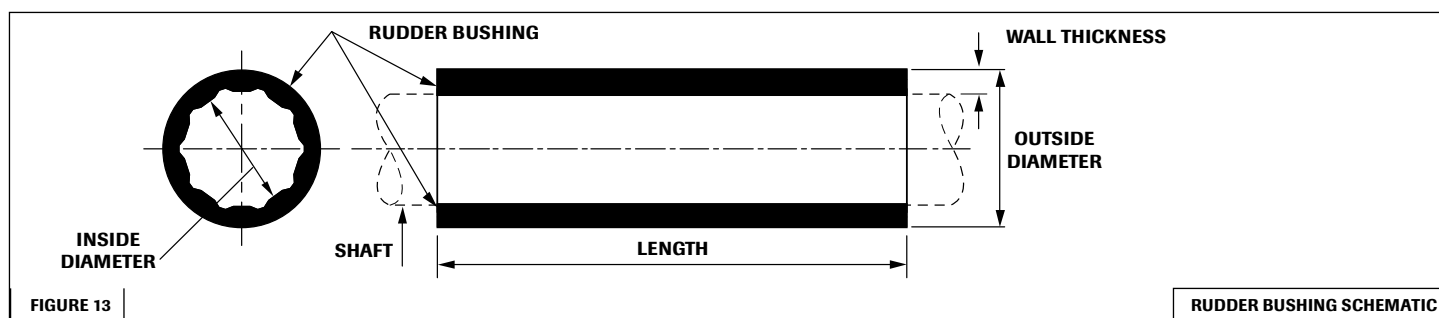

Part Number	Code	Inside Diameter Dimensions		Outside Diameter Dimensions		Length Dimensions		Wall Thickness Dimensions		Weight	
		inches	mm	inches	mm	inches	mm	inches	mm	lb.	kg.
812100038	DX150	1.45	36.83	2.35	59.69	11	279.40	1.62	41.15	1.0	0.5
812100044	DX175	1.70	43.18	2.59	65.79	13	330.20	1.97	50.04	1.5	0.7
812100051	DX200	1.95	49.53	3.07	77.98	15	381.00	2.20	55.88	2.5	1.1
812100057	DX225	2.18	55.37	3.32	84.33	7 1/2	190.50	2.57	65.28	2.3	1.0
812100064	DX250	2.44	61.98	3.68	93.47	9	228.60	2.75	69.85	2.7	1.2
812100070	DX275	2.70	68.58	3.92	99.57	10	254.00	2.97	75.44	3.0	1.4
812100076	DX300	2.95	74.93	4.20	106.68	11	279.40	3.39	86.11	4.0	1.8
812100083	DX325	3.19	81.03	4.42	112.27	12	304.80	3.60	91.44	4.0	1.8
812100089	DX350	3.34	84.84	5.19	131.83	13	330.20	3.76	95.50	7.5	3.4
812100095	DX375	3.66	92.96	5.18	131.57	14	355.60	4.05	102.87	6.5	2.9
812100102	DX400	3.93	99.82	5.45	138.43	15	381.00	4.28	108.71	7.5	3.4
812100108	DX425	4.16	105.66	5.68	144.27	16	406.40	4.55	115.57	9.0	4.1
812100114	DX450	4.42	112.27	6.02	152.91	17	431.80	4.68	118.87	11.0	5.0
812100121	DX475	4.65	118.11	6.01	152.65	18	457.20	5.05	128.27	10.0	4.5
812100127	DX500	4.93	125.22	6.68	169.67	19	482.60	5.31	134.87	15.0	6.8
812100135	DX525	5.15	130.81	6.90	175.26	20 1/2	520.70	5.64	143.26	17.0	7.7
812100140	DX550	5.39	136.91	7.61	193.29	21	533.40	5.91	150.11	21.0	9.5
812100146	DX575	5.65	143.51	7.65	194.31	22	558.80	6.00	152.40	22.0	10.0
812100152	DX600	5.87	149.10	8.65	219.71	22	558.80	6.40	162.56	24.0	10.9
812100165	DX650	6.36	161.54	8.67	220.22	22	558.80	6.84	173.74	27.8	12.6
812100171	DX675	6.65	168.91	9.00	228.60	23	584.20	7.16	181.86	31.0	14.1
812100178	DX700	6.88	174.75	9.08	230.63	24 1/2	622.30	7.35	186.69	31.0	14.1
812100184	DX725	7.10	180.34	10.47	265.94	27 1/2	698.50	7.60	193.04	38.0	17.2
812100191	DX750	7.33	186.18	10.47	265.94	27 1/2	698.50	8.07	204.98	35.0	15.9
812100197	DX775	7.70	195.58	10.47	265.94	27 1/2	698.50	8.30	210.82	45.0	20.4
812100203	DX800	7.82	198.63	10.56	268.22	29 1/2	749.30	8.50	215.90	50.0	22.7
812100216	DX850	8.37	212.60	12.20	309.88	35	889.00	9.09	230.89	65.0	29.5
812100222	DX875	8.64	219.46	11.32	287.53	32 1/2	825.50	9.11	231.39	58.0	26.3
812100229	DX900	8.89	225.81	11.32	287.53	32 1/2	825.50	9.49	241.05	73.0	33.1
812100235	DX925	9.11	231.39	12.22	310.39	35	889.00	9.72	246.89	85.0	38.6

DX490 non-metallic bushings

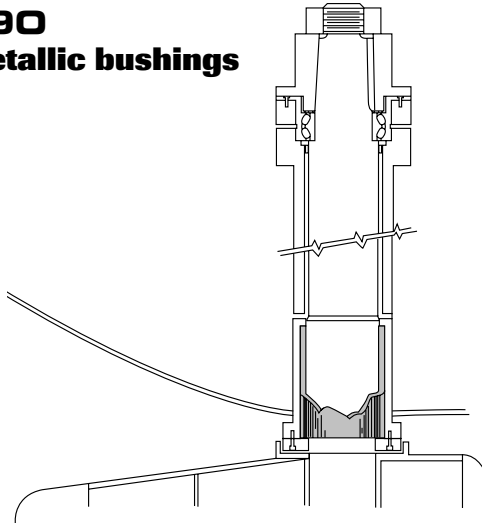

DX490 PRODUCT SPECIFICATIONS

PHYSICAL PROPERTIES:

Deformation	Load PSI	Deflection	Temperature	
	225	.004"	72° F	
	300	.0045"	72° F	
Compressive Strength	15,000	Elastic Limit	72° F	
Tensile	3000 PSI			
Expansion and Contraction	Configuration	Contraction	Temp.	Recovery
	Std. Tubular	.002" -.0025" per inch of OD	-20° F	100%
Absorption	Aging	Liquid	Temp.	Vol. Change %
	70 hrs.	ASTM #3 Oil	212° F	+ 4.9%
	70 hrs.	ASTM #3 Oil	100° F	+ less than 1%
	70 hrs.	ASTM #3 Oil	72° F	Negligible
	70 hrs.	H ₂ O	212° F	+ 2.6%
	70 hrs.	H ₂ O	100° F	Negligible
Range of working temperature - -20° to 180° continuous service.				

DX490 PRODUCT SPECIFICATIONS

CALCULATING THE FINISHED (MACHINED) SIZE OF DX490

Nominal Bushing I.D. and O.D. dimensions must be adjusted to allow for proper shaft to bearing running clearance, thermal expansion and contraction and interference press fit. Before machining, calculate the finished machined bearing I.D. and O.D. dimensions as follows:

EXAMPLE:

Nominal Shaft Diameter: 8 inches
Nominal Bearing Housing Diameter: 12 inches

To determine the finished machined bearing I.D. dimension

refer to the machining tables and add the running clearance (Table X), thermal factor (Table Y) and press fit allowance (Table Z), to the nominal shaft diameter.

Finished Machined Bearing I.D. Dimension equals:

+ Nominal Bearing Shaft Diameter 8.000
+ Running Clearance (Table X) 0.018
+ Thermal Factor (Table Y) 0.016
+ Press Fit Allowance (Table Z) 0.008
8.042 inches I.D.

To determine the finished machined bearing O.D. dimension

refer to the machining tables and add the thermal factor (Table Y) and the press fit allowance (Table Z), to the nominal bearing housing diameter.

Finished Machined Bearing O.D. Dimension equals:

+ Nominal Bearing Housing Diameter 12.000
+ Thermal Factor (Table Y) 0.016
+ Press Fit Allowance (Table Z) 0.008
12.024 inches O.D.

TABLE X – RUNNING CLEARANCE

Nominal ID inches	2	3	4	5	6	7	8	9	10	11	12	13	14
Allowance inches	0.012	0.013	0.014	0.015	0.016	0.017	0.018	0.019	0.020	0.021	0.022	0.023	0.024
Nominal ID mm	50.80	76.20	101.60	127.00	152.40	177.80	203.20	228.60	254.00	279.40	304.80	330.20	355.60
Allowance mm	0.30	0.33	0.36	0.38	0.41	0.43	0.46	0.48	0.51	0.53	0.56	0.58	0.61

TABLE Y – THERMAL FACTOR

Nominal ID inches	2	3	4	5	6	7	8	9	10	11	12	13	14
Allowance inches	0.004	0.006	0.008	0.010	0.012	0.014	0.016	0.018	0.020	0.022	0.024	0.026	0.028
Nominal ID mm	50.80	76.20	101.60	127.00	152.00	177.80	203.20	228.60	254.00	279.40	304.80	330.20	355.60
Allowance mm	0.10	0.15	0.20	0.25	0.30	0.35	0.41	0.46	0.51	0.56	0.61	0.66	0.71

TABLE Z – PRESS FIT ALLOWANCE

Nominal ID inches	2	3	4	5	6	7	8	9	10	11	12	13	14
Allowance inches	0.005	0.005	0.005	0.005	0.005	0.008	0.008	0.008	0.008	0.010	0.010	0.010	0.010
Nominal ID mm	50.80	76.20	101.60	127.00	152.00	177.80	203.20	228.60	254.000	279.40	304.80	330.20	355.60
Allowance mm	0.13	0.13	0.13	0.13	0.13	0.20	0.20	0.20	0.20	0.25	0.25	0.25	0.25

Bearing Tolerances

The following are the standards as established by the U.S. Navy, according to BuShips plan number 810-1385664, dated 14 January 1963 "Bearing Stern Tube and Strut":

Shaft or Sleeve Size	
3/4"	thru 1 3/8"
1 7/16"	thru 1 7/8"
2"	thru 2 3/8"
2 1/2"	thru 3'
3 1/8"	thru 3 3/4"
3 7/8"	thru 4 1/4"
4 3/8"	thru 4 7/8"
5"	thru 5 3/8"
5 1/2"	thru 5 7/8"
6"	thru 6 3/8"
6 1/2"	thru 6 7/8"
7"	thru 7 3/8"
7 1/2"	thru 7 7/8"
8"	thru 8 3/8"
8 1/2"	thru 8 7/8"
9"	thru 9 7/8"
10"	thru 10 7/8"
11"	thru 11 3/8"
11 1/2"	thru 12 3/4"
12 7/8"	thru 13 3/8"
13 1/2"	thru 14 1/2"
14 5/8"	thru 15"

Shaft Clearance	
+ 0.003	to + 0.008
+ 0.004	to + 0.010
+ 0.006	to + 0.012
+ 0.007	to + 0.014
+ 0.008	to + 0.015
+ 0.010	to + 0.017
+ 0.012	to + 0.019
+ 0.015	to + 0.023
+ 0.017	to + 0.025
+ 0.020	to + 0.029
+ 0.022	to + 0.032
+ 0.024	to + 0.034
+ 0.025	to + 0.035
+ 0.027	to + 0.037
+ 0.028	to + 0.040
+ 0.030	to + 0.042
+ 0.032	to + 0.044
+ 0.034	to + 0.048
+ 0.035	to + 0.050
+ 0.037	to + 0.052
+ 0.040	to + 0.055
+ 0.042	to + 0.058

O.D. Tolerance			
1 1/4"	thru 2"	+ .001	to - .001
2"	thru 6"	+ .002	to - .001
6"	thru 7 1/2"	+ .002	to - .002
7 3/4"	thru 12"	+ .005	to - .005
12"	thru 16"	+ .006	to - .006
16"	thru 18"	+ .008	to - .008

ALL DIMENSIONS IN INCHES

Bearing and Journal Wear

All bearings and journals experience wear in service and especially those located adjacent to the ship's propeller. New bearings properly fitted to the shaft journal wear more slowly when run in clean water. Where the lubricant water is more heavily contaminated with entrained abrasives the wearing is more rapid. Bearings thus exposed should be inspected at least annually, or during each haul out to determine actual wear. For optimum vessel service a program of good bearing maintenance combined with timely replacement or relining of worn bearings is a must.

Relining Service Available

Flanged Bearings can be relined if the metal shells are not damaged or distorted. The old rubber lining is removed from the bearing and the metal shell is cleaned for the vulcanization of the new rubber bearing surface to the metal I.D. The following conditions apply for the relining of Flanged Bearings.

- A.** All returned Flanged Bearings are subject to inspections and acceptance for relining.
- B.** The factory must be notified prior to the return of the bearing for relining.
- C.** All Bearings must be boxed for protection from damage in transit. The liability of which rests with the shipper and carrier.
- D.** Mark Bearing and boxes with the following instructions:
 1. Name of Vessel
 2. Owner of Vessel
 3. Name of Company returning Bearing

- E.** Bearing to be relined should be shipped PRE-PAID freight allowed to:

Duramax® Marine LLC
 17990 Great Lakes Parkway
 Hiram, OH 44234
 Collect Shipments Will Not Be Accepted.

- F.** A copy of the Bill of Lading and all correspondence regarding relining should be mailed to:

Duramax® Marine LLC
 17990 Great Lakes Parkway
 Hiram, OH 44234



DURAMAX® MARINE BEARINGS

Johnson Cutless® Sleeve Bearings
Johnson Cutless® Flanged Bearings
Johnson Cutless® Demountable Rubber Stave Bearings
Romor® I Bearing Staves
Romor® Segmental Housings
Duramax® “490” Rudder Bushings
Duramax® Industrial Bearings



DURAMAX® MARINE HEAT EXCHANGE SYSTEMS

Johnson Demountable Keel Coolers
DuraCooler® Keel Coolers
Duramax® Box Coolers



DURAMAX® MARINE FENDERING SYSTEMS

Johnson Commercial Dock Bumpers
Johnson Tow Knees
LINERITE®* II composite batterboard systems
Johnson Weatherstrip Door Gaskets,
Window Channel and Hatch Cover Gaskets

*LINERITE® is a registered trademark of the BF Goodrich Company



DURAMAX® MARINE SEALING SYSTEMS

Duramax® Shaft Seal System
Johnson Stuffing Boxes
Duramax® “Strong Boy” Stern Castings and Stuffing Boxes

17990 Great Lakes Parkway
Hiram, Ohio 44234 U.S.A.

PHONE 440.834.5400

FAX 800.497.9283 *USA & Canada*
or 440.834.4950

E-MAIL info@duramaxmarine.com

WEB www.duramax-marine.com

DURAMAX® MARINE LLC